

## *The easy way to order brake lines*

*Sample on measuring hose with banjofittings in both ends ex.*

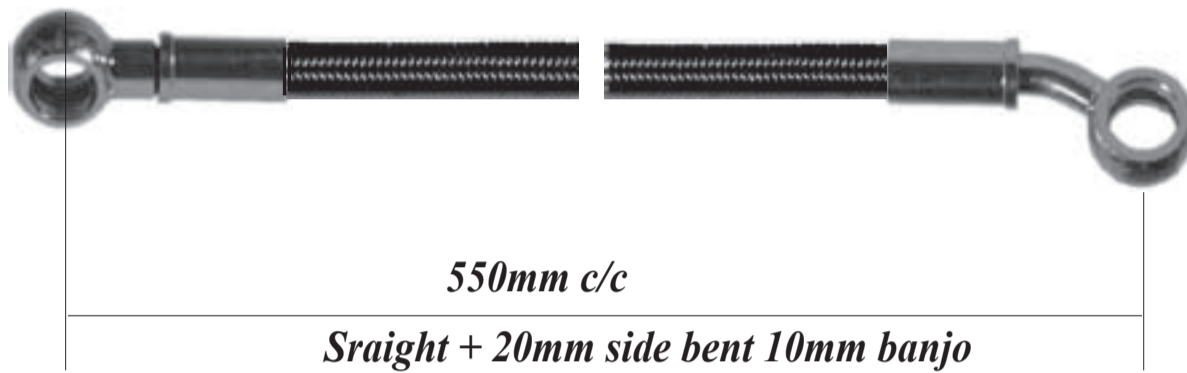

*The fittings are adjustable after crimping*





Stainless Braided Teflon Hose (is also available in different coloured plastic cover)  
Results in a firmer brake pedal. Improved brake pedal "feeling"  
and better brake modulation.

Diffusion tight, means no more water in the brake fluid.

Age constant, (rubber gets dry and cracks during time) is compatible with  
all brake and clutch fluids.

### **2807-03**

Weight: 65g/m  
Measure: id 3,4mm yd 6,3mm  
Working Pressure: 320 bar (Burst Pressure 960 bar)  
Bend Radius: 38mm  
Temp: -60 - +260° C

**2807-03CL = Transparent**  
**2807-03BU = Transparent Blue**  
**2807-03CB = Cevlar look Transparent**  
**2807-03RD = Red**  
**2807-03BK = Black**  
**2807-03OR = Orange**  
**2807-03YE = Yellow**

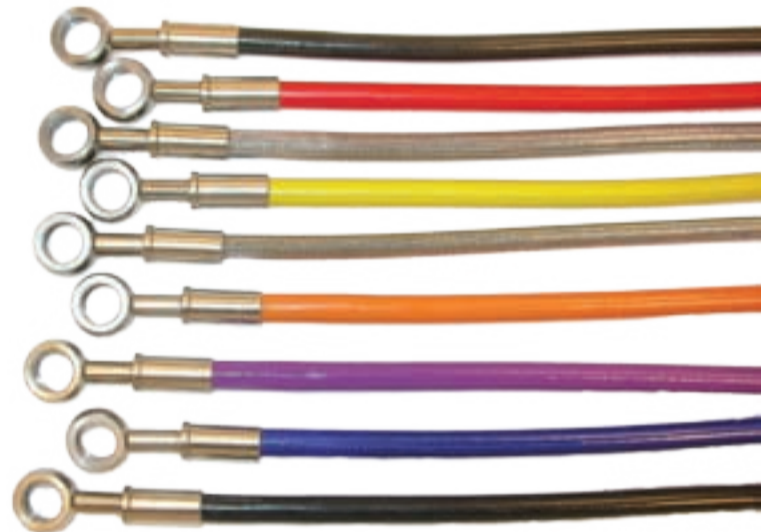

Weight: 78g/m  
Measure: id 3,4mm yd 7,6mm  
Working Pressure: 320 bar (Burst Pressure 960 bar)  
Bend Radius: 38mm  
Temp: -60 - +260° C

### **2807-04**

Weight: 70g/m  
Measure: id 4,8mm yd 7,6mm  
Working Pressure: 205 bar (Burst Pressure 620 bar)  
Bend Radius: 51mm  
Temp: -60 - +260° C



**Please Read :**

The Fittings are adjustable after crimping, which means that you can afterwards adjust the angle between two fittings if necessary.

The best way is to mount one fitting and use a tong to turn the ferrule to the correct angle.

To explain the part numbers:

xxxx-xx-xx The four first numbers is for fitting type

Next two numbers is for dimension or size of thread on connection.

ex.

banjo fitting:            XXXX-08-XX = 8mm banjo  
                                   XXXX-10-XX = 10mm banjo osv.

mm threaded connection:    XXXX-21-XX = M8x1  
                                           XXXX-22-XX = M8x1,25  
                                           XXXX-31-XX = M10x1  
                                           XXXX-32-XX = M10x1,25  
                                           XXXX-35-XX = M10x1,5  
                                           XXXX-41-XX = M12x1  
                                           XXXX-42-XX = M12x1,25  
                                           XXXX-45-XX = M12x1,5  
                                           XXXX-52-XX = M14x1,25  
                                           XXXX-55-XX = M14x1,5

inch threaded connection:	JIC/UNF	NPTF	BSP
	XXXX-02-XX = 5/16-24		
	XXXX-03-XX = 3/8-24	1/8-27	1/8-28
	XXXX-04-XX = 7/16-20	1/4-18	1/4-19
	XXXX-05-XX = 1/2-20		
	XXXX-06-XX = 9/16-18	3/8-18	3/8-19
	XXXX-07-XX = 5/8-18		
	XXXX-08-XX = 3/4-16	1/2-14	1/2-14
	XXXX-10-XX = 7/8-14		5/8-14

The last two numbers is for

Dimension on hose end:    XXXX-XX-03 = 1/8  
                                           XXXX-XX-04 = 3/16

# Crimp Fittings unf

C = Stainless



Female Swivel

Part no	Thread
6103-03-03	3/8-24 conc
6103-03-03C	3/8-24 conc
6103-04-03	7/16-20 conc
6103-04-03C	7/16-20 conc
6103-04-04	7/16-20 conc



Male Swivel

Part no	Thread
6104-03-03	3/8-24 conc
6104-03-03C	3/8-24 conc
6104-07-03	7/16-24 conc



Male Swivel

Part no	Thread
6105-03-03	3/8-24 conv
6105-03-03C	3/8-24 conv



Female Swivel

Part no	Thread
6117-03-03	3/8-24 conc 45°
6117-03-03C	3/8-24 conc 45°
6117-04-03	7/16-20 conc 45°
6117-04-04	7/16-20 conc 45°
6117-04-04C	7/16-20 conc 45°



Male Swivel

Part no	Thread
6193-03-03	3/8-24 ur conc 45°
6193-03-03C	3/8-24 ur conc 45°



Male Swivel

Part no	Thread
6155-03-03	3/8-24 conv 45°
6155-03-03C	3/8-24 conv 45°



Female Swivel

Part no	Thread
6191-03-03	3/8-24 conc 90°
6191-03-03C	3/8-24 conc 90°
6191-04-03	7/16-20 conc 90°
6191-04-04	7/16-20 conc 90°
6191-04-04C	7/16-20 conc 90°



Male Swivel

Part no	Thread
6194-03-03	3/8-24 conc 90°
6194-03-03C	3/8-24 conc 90°



Male Swivel

Part no	Thread
6195-03-03	3/8-24 conv 90°
6195-03-03C	3/8-24 conv 90°



# Crimp Fittings unf

C = Stainless



**Male**

Part no	Thread
6144-03-03	3/8-24 conv



**Male**

Part no	Thread
6114-03-03	3/8-24 conc
6114-03-03C	3/8-24 conc



**Male**

Part no	Thread
6132-04-03	7/16-20 conc/conc



**Male**

Part no	Thread
6132-04-03L	7/16-20 conc



**Female Swivel**

Part no	Thread
6141-07-03	7/16-24 conc
6141-07-04	7/16-24 conc
6142-07-03	7/16-24 conv
6142-07-04	7/16-24 conv
6142-17-03	7/16-20 conv



**Female Swivel**

Part no	Thread
6141-03-03	3/8-24 conc
6141-03-03C	3/8-24 conc
6142-03-03	3/8-24 conv
6142-03-03C	3/8-24 conv



**Male**

Part no	Thread
6133-04-03	7/16-20 conc



**Male**

Use Lock nut 924-03

Part no	Thread
6145-03-03	3/8-24 bulkhead conv
6145-03-03C	3/8-24 bulkhead conv



**Male / Female**

Use Lock nut 2K8686

Part no	Thread
6741-03-03	3/8-24 conc 5/8 male
6741-03-03C	3/8-24 conc 5/8 male
6742-03-03	3/8-24 conv 5/8 male



**Female**

Part no	Thread
6150-03-03	3/8-24 conv

# *Crimp Fittings mm*

C = Stainless



**Female**

Part no	Thread
6101-31-03	M10 x 1 conc
6101-31-03C	M10 x 1 conc



**Female Swivel**

Part no	Thread
6103-31-03	M10 x 1 conc
6321-31-03	M10 x 1 conv



**Male Swivel**

Part no	Thread
6104-31-03	M10 x 1 conc
6104-31-03C	M10 x 1 conc
6104-32-03	M10 x 1,25 conc
6104-32-03C	M10 x 1,25 conc



**Male Swivel**

Part no	Thread
6105-31-03	M10 x 1 conv
6105-31-03C	M10 x 1 conv
6105-32-03	M10 x 1,25 conv
6105-32-03C	M10 x 1,25 conv



**Male**

Part no	Thread
6123-31-03	M10 x 1 conc
6123-31-03C	M10 x 1 conc
6123-32-03	M10 x 1,25 conc
6123-32-03C	M10 x 1,25 conc



**Female Swivel**

Part no	Thread
6141-31-03	M10 x 1 conc
6141-31-03C	M10 x 1 conc
6141-32-03	M10 x 1,25 conv
6141-32-03C	M10 x 1,25 conv
6142-31-03	M10 x 1 conv
6142-31-03C	M10 x 1 conv
6142-32-03	M10 x 1,25 conv
6142-32-03C	M10 x 1,25 conv

# *Crimp Fittings mm*

C = Stainless



**Female Swivel**

Part no	Thread
6141-31-03RC	M10 x 1 conc
6142-31-03RC	M10 x 1 conv



**Female Swivel**

Part no	Thread
6141-31-03T	M10 x 1 conc
6142-31-03T	M10 x 1 conv

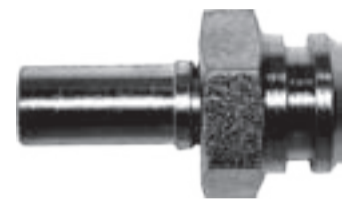

**Female Swivel**

Part no	Thread
6141-31-03Z	M10 x 1 conc
6142-31-03Z	M10 x 1 conv



**Male**

Part no	Thread
6144-31-03	M10 x 1 conv
6144-31-03C	M10 x 1 conv
6144-32-03	M10 x 1,25 conv
6144-32-03C	M10 x 1,25 conv



**Male**

Part no	Thread
6132-41-03	M12 x 1 conc/conv



**Female Swivel**

Part no	Thread
6141-41-03	M12 x 1 conc
6141-41-04	M12 x 1 conc
6142-41-03	M12 x 1 conv
6142-41-04	M12 x 1 conv

# *Crimp Fittings mm*

C = Stainless



**Female Swivel**



**Male Swivel**



**Male Swivel**

Part no	Thread
6117-31-03	M10 x 1 conc 45°

Part no	Thread
6154-31-03	M10 x 1 conc 45°
6154-31-03C	M10 x 1 conc 45°
6154-32-03	M10 x 1,25 conc 45°

Part no	Thread
6155-31-03	M10 x 1 conv 45°
6155-31-03C	M10 x 1 conv 45°
6155-32-03	M10 x 1,25 conv 45°
6155-32-03C	M10 x 1,25 conv 45°



**Female Swivel**



**Male Swivel**



**Male Swivel**

Part no	Thread
6191-31-03	M10 x 1 conc 90°

Part no	Thread
6194-31-03	M10 x 1 conc 90°
6194-31-03C	M10 x 1 conc 90°
6194-32-03	M10 x 1,25 conc 90°
6194-32-03C	M10 x 1,25 conc 90°

Part no	Thread
6195-31-03	M10 x 1 conv 90°
6195-31-03C	M10 x 1 conv 90°
6195-32-03	M10 x 1,25 conv 90°
6195-32-03C	M10 x 1,25 conv 90°



# *Crimp Fittings mm*

C = Stainless



**Female Swivel**

Part no	Thread
6141-31-03A	M10 x 1 conc AUDI



**Female Swivel**

Part no	Thread
6141-31-03P	M10 x 1 conc Porsche



**Male**

Part no	Thread
6144-31-03L	M10 x 1 conv/conc BMW



**Female**

Part no	Thread
6150-31-03VR	M10 x 1 conc Viper



**Female Swivel**

Part no	Thread
6743-31-03	M10 x 1 conv Toyota



**Female Swivel**

Part no	Thread
6744-31-03	M10 x 1 conv Toyota



**Female Swivel**

Part no	Thread
6745-31-03	M10 x 1 conv Subaru



**Female Swivel**

Part no	Thread
6746-31-03	M10 x 1 conc Audi TT

# Crimp Fittings mm

C = Stainless



Male

Part no	Thread
6144-31-03EXT	M10 x 1 conv extended



Male

Use Lock Nut 318-31

Part no	Thread
6145-31-03	M10 x 1 conc bulkhead
6145-31-03C	M10 x 1 conc bulkhead



Male

Use Lock Nut 318-31

Part no	Thread
6143-31-03	M10 x 1 conv bulkhead
6143-31-03C	M10 x 1 conv bulkhead
6143-41-04	M12 x 1 conv bulkhead



Female

Use Lock Nut 2K8686

Part no	Thread
6741-31-03	M10 x 1 conc 5/8 male
6741-31-03C	M10 x 1 conc 5/8 male
6742-31-03	M10 x 1 conv 5/8 male
6742-31-03C	M10 x 1 conv 5/8 male



Female Swivel

Part no	Thread
6129-45-03	M12 x 1,5 spherical seat
6129-55-03	M14 x 1,5 spherical seat

# Crimp Fittings mm

C = Stainless



Part no	Dia ø
6192-08-03	Banjo 8mm
6192-10-03	Banjo 10mm
6192-10-03C	Banjo 10mm
6192-11-03	Banjo 11mm
6192-11-03C	Banjo 11mm
6192-12-03	Banjo 12mm
6192-10-04	Banjo 10mm

Part no	Dia ø
6192-10-03ML	Banjo 10mm med.long
6192-10-03MLC	Banjo 10mm med.long
6192-10-03L	Banjo 10mm long
6192-10-03LC	Banjo 10mm long
6192-11-03ML	Banjo 11mm med.long
6192-11-03MLC	Banjo 11mm med.long
6192-10-04ML	Banjo 10mm med.long
6192-11-04L	Banjo 10mm long

Part no	Dia ø
6193-10-03	Banjo 10mm 20°
6193-10-03C	Banjo 10mm 20°
6193-11-03	Banjo 11mm 20°
6193-11-03C	Banjo 11mm 20°
6196-10-03	Banjo 10mm 35°
6196-10-03C	Banjo 10mm 35°
6194-10-03	Banjo 10mm 45°
6194-10-03C	Banjo 10mm 45°
6170-10-03	Banjo 10mm 70°
6170-10-03C	Banjo 10mm 70°
6193-10-04	Banjo 10mm 20°
6194-10-04	Banjo 10mm 45°
6170-10-04	Banjo 10mm 70°



Part no	Dia ø
6197-10-03	Banjo 10mm 20° side
6197-10-03C	Banjo 10mm 20° side
6297-10-03	Banjo 10mm 75° side
6297-10-03C	Banjo 10mm 75° side
6299-10-03	Banjo 10mm 90° side
6299-10-03C	Banjo 10mm 90° side

Part no	Dia ø
6199-10-03	Banjo 10mm 90°
6199-10-03C	Banjo 10mm 90°
6199-11-03	Banjo 11mm 90°
6199-11-03C	Banjo 11mm 90°
6199-10-04	Banjo 10mm 90°



Part no	Dia ø
6193-10-03B	Banjo 10mm 15° Block

Part no	Dia ø
6198-10-03	Banjo 10mm Double
6198-10-03C	Banjo 10mm Double

# Crimp Fittings bsp

C = Stainless



Female Swivel

Part no	Thread
6321-03-03	1/8 bsp conv
6321-03-03C	1/8 bsp conv



Female Swivel

Part no	Thread
6331-03-03	1/8 bsp conv 45°



Female Swivel

Part no	Thread
6332-03-03	1/8 bsp conv 90°

# Minimess



Female Swivel

Part no	Thread
6101-04-03	1/4 bsp Flat seal

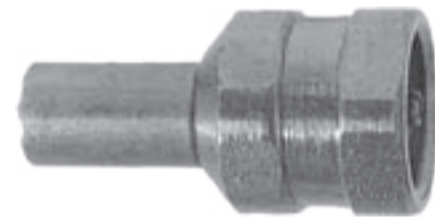

Female Swivel

Part no	Thread
6101-62-03	M16 x 2 minimess

# Crimp Fittings NPT



Male Swivel

Part no	Thread
6102-03-03	1/8 NPT



# Adapters

C = Stainless



Part no	Thread
816-03	3/8-24 x 1/8 npt
816-03C	3/8-24 x 1/8 npt

Part no	Thread
823-03	3/8-24 x 1/8 npt 45°
823-03C	3/8-24 x 1/8 npt 45°

Part no	Thread
822-03	3/8-24 x 1/8npt 90°
822-03C	3/8-24 x 1/8npt 90°



Part no	Thread
825-03	3/8-24 x 1/8 npt T
825-03C	3/8-24 x 1/8 npt T

Part no	Thread
826-03	3/8-24 x 1/8 npt T



Part no	Thread
763-03-03	3/8-24 unf conv x 1/8 npt
763-03-04	7/16-20 unf conv x 1/8 npt

Part no	Thread
835-03	1/8 npt x 3/8-24 if conv
835-04	7/16-24 if x 1/8 NPT
835-05	1/2-20 if x 1/8 NPT
835-06	5/8-18 if x 1/4 NPT
835-07	3/4-18 if x 3/8 NPT

Part no	Thread
836-03	1/8 npt x 3/8-24 conv 90°

# Adapters

C = Stainless



Part no	Thread
837-03	3/8-24 unf conv bulkhead 45°

Part no	Thread
833-03	3/8-24 unf conv bulkhead 90°
833-03C	3/8-24 unf conv bulkhead 90°



Part no	Thread
832-03	3/8-24 unf conv bulkhead
832-03C	3/8-24 unf conv bulkhead
307-03-31	M10 x 1 conv bulkhead

Part no	Thread
804-03	3/8-24 unf conv bulkhead
804-03C	3/8-24 unf conv bulkhead



Part no	Thread
924-03	3/8-24 Lock Nut
924-03C	3/8-24 Lock Nut
2K8686	5/8 W Lock Nut
318-31	M10 x 1 Lock Nut

Part no	Thread
834-03	3/8-24 unf conv bulkhead
834-03C	3/8-24 unf conv bulkhead

# Adapters

C = Stainless



Part no	Thread
815-03	3/8-24 Equal
815-03C	3/8-24 Equal

Part no	Thread
9821-03	3/8-24 Equal 90°

Part no	Thread
824-03	3/8-24 T
824-03C	3/8-24 T



Part no	Thread
305-03-21	3/8-24 unf conv x M8 x 1 conv
305-03-21C	3/8-24 unf conv x M8 x 1 conv
305-03-31	3/8-24 unf conv x M10 x 1 conv
305-03-31C	3/8-24 unf conv x M10 x 1 conv
305-03-32	3/8-24 unf conv x M10 x 1,25 conv
305-03-41	3/8-24 unf conv x M12 x 1 conv
305-03-41C	3/8-24 unf conv x M12 x 1 conv
305-03-42	3/8-24 unf conv x M12 x 1,25 conv
305-03-45	3/8-24 unf conv x M12 x 1,5 conv
305-03-45C	3/8-24 unf conv x M12 x 1,5 conv
305-04-31	7/16-20 unf conv x M10 x 1 conv
305-04-41	7/16-20 unf conv x M12 x 1 conv

Part no	Thread
306-03-21	3/8-24 unf conv x M8 x 1 conc
306-03-31	3/8-24 unf conv x M10 x 1 conc
306-03-32	3/8-24 unf conv x M10 x 1,25 conc
306-03-35	3/8-24 unf conv x M10 x 1,5 conc
306-03-41	3/8-24 unf conv x M12 x 1 conc
306-03-45	3/8-24 unf conv x M12 x 1,5 conc
306-03-55	3/8-24 unf conv x M14 x 1,5 conc
306-03-08	3/8-24 unf conv x M18 x 1,5 conc



Part no	Thread
707-03-04	3/8-24 unf conv x 7/16-20 conc
707-03-05	3/8-24 unf conv x 1/2-20 conc
707-03-06	3/8-24 unf conv x 9/16-18 conc
707-03-07	3/8-24 unf conv x 7/16-24 conc
815-03V	3/8-24 unf conv x 3/8-24 conc
815-03VL	3/8-24 unf conv x 3/8-24 conc long

Part no	Thread
742-03-31	M10 x 1 conc x R 1/8 bsp conc
742-03-32	M10 x 1,25 conc x R 1/8 bsp conc
741-03-03V	3/8-24 conc x R 1/8 bsp conc

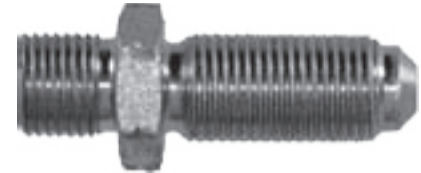

# Adapters

Part no	Thread
945-03-31	R 1/8 bsp conc x M10 x 1 conv
945-03-32	R 1/8 bsp conc x M10 x 1,25 conv
741-03-03	R 1/8 bsp conc x 3/8-24 conv

Part no	Thread
946-03-31	R 1/8 bsp conc x M10 x 1 conv
743-03-03	R 1/8 bsp conc x 3/8-24 conv



Part no	Thread
972052	3/8-24 conv

Part no	Thread
918-01	1/8 npt if 4 way

Part no	Thread
220-303	3/8-24 if conc
320-041	M12 x 1 conv

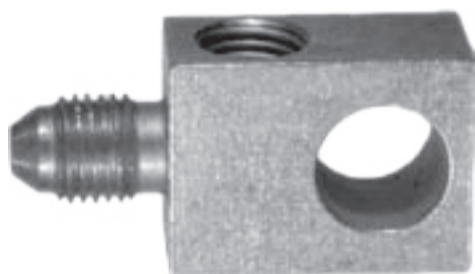

Part no	Thread
G105A	3/8-24 conv

Part no	Thread
220-403	3/8-24 conc 4 way

Part no	Thread
319-031	M10 x 1 conc



# Banjo Bolts

C = Stainless



Part no	Thread
992-03-21	M8 x 1 banjo bolt
992-03-31	M10 x 1 banjo bolt
992-03-31C	M10 x 1 banjo bolt
992-03-32	M10 x 1,25 banjo bolt
992-03-32C	M10 x 1,25 banjo bolt
992-03-35	M10 x 1,5 banjo bolt
992-03-35C	M10 x 1,5 banjo bolt
992-04M121	M12 x 1 banjo bolt
992-04-42	M12 x 1,25 banjo bolt
992-04-45	M12 x 1,5 banjo bolt
992-06-55	M14 x 1,5 banjo bolt
992-06-65	M16 x 1,5 banjo bolt



Part no	Thread
775-03	3/8-24 banjo bolt
775-03C	3/8-24 banjo bolt
775-04	7/16-20 banjo bolt
775-04C	7/16-20 banjo bolt
775-06	9/16-18 banjo bolt
977-522	7/16-24 banjo bolt
1012-03	R1/8 banjo bolt



Part no	Thread
993-03-21	M8 x 1 banjo bolt double
993-03-31	M10 x 1 banjo bolt double
993-03-31C	M10 x 1 banjo bolt double
993-03-32	M10 x 1,25 banjo bolt double
993-03-32C	M10 x 1,25 banjo bolt double
993-04-45	M12 x 1,5 banjo bolt double
993-06-55	M14 x 1,5 banjo bolt double
993-06-65	M16 x 1,5 banjo bolt double



Part no	Thread
773-03	3/8-24 banjo bolt double
773-03C	3/8-24 banjo bolt double
1013-03	R1/8 banjo bolt double



Part no	Thread
BK992-03-31	M10 x 1 brake light switch
BK992-03-32	M10 x 1,25 brake light switch
BK992-03-03	3/8-24 unf brake light switch



Part no	Thread
BK993-03-31	M10 x 1 brake light switch double
BK993-03-32	M10 x 1,25 brake light switch double

# Accessories

C = Stainless



Part no	Dia ø
776-03	3/8-24 x 10mm banjo
776-03-04	3/8-24 x 11mm banjo



Part no	Dia ø
779-03	3/8-24 x 10mm banjo



Part no	Thread
314-031	M10 x 1 Plugg



Part no	Thread
932-02	1/8 NPT Plugg Insex

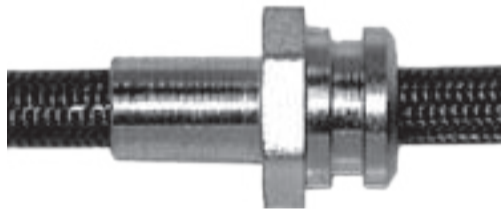

Part no	Line Locator
BLT1	Line Locator



Part no	Line Locator
BLT2	Line Locator



Part no	Line Locator
BLT3	Line Locator



Part no	Line Locator
BLT4	Line Locator



Part no	Line Locator
BLT301NY	Line Locator

# Accessories

C = Stainless



Part no	
BLT302NY	Line Locator

Part no	Dia ø
819-03	3/16 Tube Sleeve
819-03C	3/16 Tube Sleeve
819-04	1/4 Tube Sleeve
819-04C	1/4 Tube Sleeve

Part no	Dia ø
6100-00-03	Crimp Ferruel 1/8" Crimp Dim 8,0mm
6100-00-03C	Crimp Ferruel 1/8" Crimp Dim 8,0mm



Part no	Dia ø
6100-00-04	Crimp Ferruel 3/16" Crimp Dim 9,5mm
6100-00-04C	Crimp Ferruel 1/8" Crimp Dim 9,5mm

Part no	Thread
818-03	3/8-24 Nut
818-03C	3/8-24 Nut
818-04	7/16-20 Nut
818-04C	7/16-20 Nut

Part no	Dia ø
445-16	10mm Copper Crush Washers
445-18	11mm Copper Crush Washers
445-19	12mm Copper Crush Washers



Brake / Fuel Stainless Steel Tubing

Part no	Dia ø
6100-00-00	1/8 Whip Guard

Part no	Dim.
SS316	3/16
SS014	1/4
SS038	3/8



# Brake System



**Tilton Master Cylinder Kit**

Part no	Dim.
74-625U	0,625" = 15,87mm
74-700U	0,700" = 17,78mm
74-750U	0,750" = 19,05mm
74-812U	0,812" = 20,62mm
74-875U	0,875" = 22,22mm
74-1000U	1,0" = 25,4mm
74-1125U	1,125" = 28,57mm

**Tilton Master Cylinder Kit**

Part no	Dim.
75-625U	0,625" = 15,87mm
75-700U	0,700" = 17,78mm
75-750U	0,750" = 19,05mm
75-812U	0,812" = 20,62mm
75-875U	0,875" = 22,22mm
75-1000U	1,0" = 25,4mm
75-1125U	1,125" = 28,57mm





# Brake System



**Brake Fluid Container**  
 ø 55mm Height 50mm  
 Thread AN -04 = 7/16-20

**Part no**  
**70005**



**Brake Fluid Container**  
 ø 55mm Height 70mm  
 Thread AN -04 = 7/16-20

**Part no**  
**70007**



**Girling Master Cylinder**

Part no	Dim.
70-162	0,625" = 15,87mm
70-170	0,700" = 17,78mm
70-175	0,750" = 19,05mm



**Residual Pressure Valve**  
 Blue = 2 lbs = 0,9bar

Part no	Thread
90-1874	1/8 NPT Female

# Brake System



Remote controll for Balance Bar

**Part no**  
**72-501**



Balance Bar Assembly  
with 3/8-24 Therad

**Part no**  
**72-250**



Proportioning Valve  
with Lever Tilton

**Part no**  
**90-100**



Proportioning Valve  
Rotory Style Tilton

**Part no**  
**90-200**



Proportioning Valve  
Rotory Style Wilwood

**Part no**  
**901-220**





**Fuel & Oil Hose**

**Stainless Steel Braided Rubber**



In recent years fuel manufactures has add different unpublished additives in their fuel, as a result of this it is impossible to say how this will affect the rubber in our or others rubber hose.

**"It is impossible to guarantee use without problem with the rubber hose"**

If in doubt use Teflon Hose.

**Stainless Steel Braided  
Working.temp. -46°C to +150°C**

Part no	Bore Size mm	Braid O/D mm	Bend Radius mm	Working Pressure bar	Weight Kg/m
300-04	5,56	11,11	50	102	0,169
300-05	6,35	12,70	50	102	0,190
300-06	8,75	13,89	64	102	0,200
300-07	9,52	15,09	76	102	0,240
300-08	11,12	16,35	89	102	0,271
300-10	14,32	20,30	102	85	0,348
300-11	15,28	21,55	110	70	0,360
300-12	17,33	24,00	115	70	0,420
300-14	19,05	26,20	125	60	0,495
300-16	22,20	29,20	140	50	0,565
300-18	25,40	33,40	175	40	0,650
300-20	28,70	35,80	205	35	0,730
300-24	34,05	43,20	225	20	1,190
300-28	38,10	47,00	255	15	1,340
300-32	44,45	54,00	305	14	1,458

*Note. Pressure limit factor is for the hose  
(With mounted fittings is maximum pressure 17bar)*



**Straight Female Swivel**

Part no	Hose Size	JIC/UNF Thread
8001-06	-06	9/16 x 18
8001-08	-08	3/4 x 16
8001-10	-10	7/8 x 14
8001-12	-12	1 1/16 x 12
8001-16	-16	1 5/16 x 12

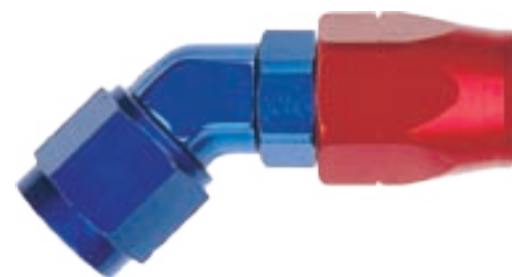

**45° Female Forged Elbow**

Part no	Hose Size	JIC/UNF Thread
8045-06	-06	9/16 x 18
8045-08	-08	3/4 x 16
8045-10	-10	7/8 x 14
8045-12	-12	1 1/16 x 12
8045-16	-16	1 5/16 x 12

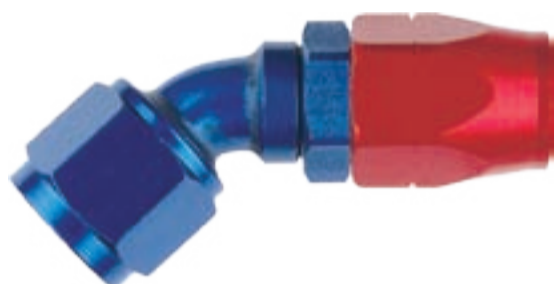

**45° Female Swept Tube**

Part no	Hose Size	JIC/UNF Thread
8046-06	-06	9/16 x 18
8046-08	-08	3/4 x 16
8046-10	-10	7/8 x 14
8046-12	-12	1 1/16 x 12
8046-16	-16	1 5/16 x 12



**90° Female Forged Elbow**

Part no	Hose Size	JIC/UNF Thread
8090-06	-06	9/16 x 18
8090-08	-08	3/4 x 16
8090-10	-10	7/8 x 14
8090-12	-12	1 1/16 x 12
8090-16	-16	1 5/16 x 12

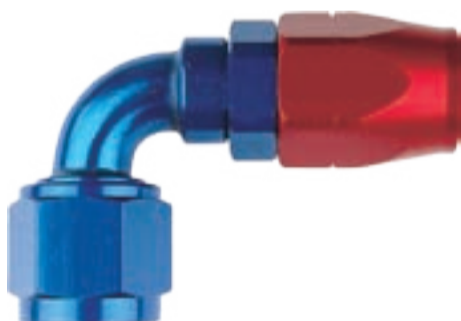

**90° Female Swept Tube**

Part no	Hose Size	JIC/UNF Thread
8091-06	-06	9/16 x 18
8091-08	-08	3/4 x 16
8091-10	-10	7/8 x 14
8091-12	-12	1 1/16 x 12
8091-16	-16	1 5/16 x 12



**120° Female Swept Tube**

Part no	Hose Size	JIC/UNF Thread
8120-06	-06	9/16 x 18
8120-08	-08	3/4 x 16
8120-10	-10	7/8 x 14
8120-12	-12	1 1/16 x 12
8120-16	-16	1 5/16 x 12



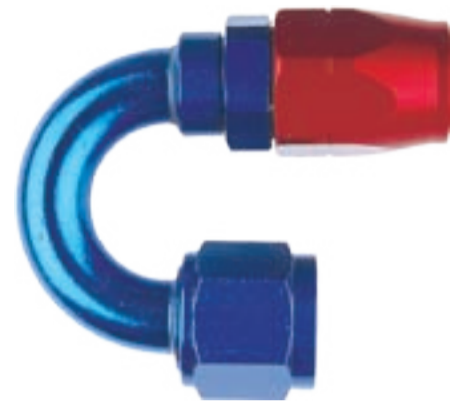

**150° Female Swept Tube**

Part no	Hose Size	JIC/UNF Thread
8150-06	-06	9/16 x 18
8150-08	-08	3/4 x 16
8150-10	-10	7/8 x 14
8150-12	-12	1 1/16 x 12
8150-16	-16	1 5/16 x 12

**180° Female Swept Tube**

Part no	Hose Size	JIC/UNF Thread
8180-06	-06	9/16 x 18
8180-08	-08	3/4 x 16
8180-10	-10	7/8 x 14
8180-12	-12	1 1/16 x 12
8180-16	-16	1 5/16 x 12



**Stright Banjo**

Part no	Hose Size	Bolt Thread
8076-91	-06	M12 x 1,25
8076-92	-06	M12 x 1,5
8076-94	-06	9/16-24
8076-95	-06	1/2-20



**Stright Double Banjo**

Part no	Hose Size	Bolt Thread
8079-91	-06	M12 x 1,25
8079-92	-06	M12 x 1,5
8079-94	-06	9/16-24
8079-95	-06	1/2-20



**Stright Male**

Part no	Hose Size	NPT Thread
3201-04	-04	1/8
3201-44	-04	1/4
3201-62	-06	1/8
3201-06	-06	1/4
3201-66	-06	3/8
3201-07	-08	1/4
3201-08	-08	3/8
3201-88	-08	1/2
3201-11	-10	3/8
3201-10	-10	1/2
3201-12	-12	3/4
3201-13	-12	1/2



**Tube-Mate Auto-Fit**

Part no	Hose Size	Tube Size
3601-04	-04	1/4
3601-65	-06	5/16
3601-06	-06	3/8
3601-08	-08	1/2
3601-10	-10	5/8
3601-12	-12	3/4



**Fuel & Oil Hose**

**Synthetic Rubber Tube**

**Textile braid reinforcement and synthetic rubber cover**

**"Push on" Hose is a high quality hose for fuel and lubrication oil, air and water.  
Constructed for use with the "Push On" fittings without clamp**



**Synthetic Rubber Cover**  
**One layer Textile braid reinforcement**  
**Temp range -40°C to +150°C**

Part no	Bore Size mm	Braid O/D mm	Bend Radius mm	Working Pressure bar	Weight Kg/m
2556-04	6,35	12,70	76	17	0,119
2556-06	9,65	15,75	76	17	0,163
2556-08	12,70	19,05	127	17	0,238
2556-10	15,75	23,10	152	17	0,297
2556-12	19,05	26,15	178	17	0,342

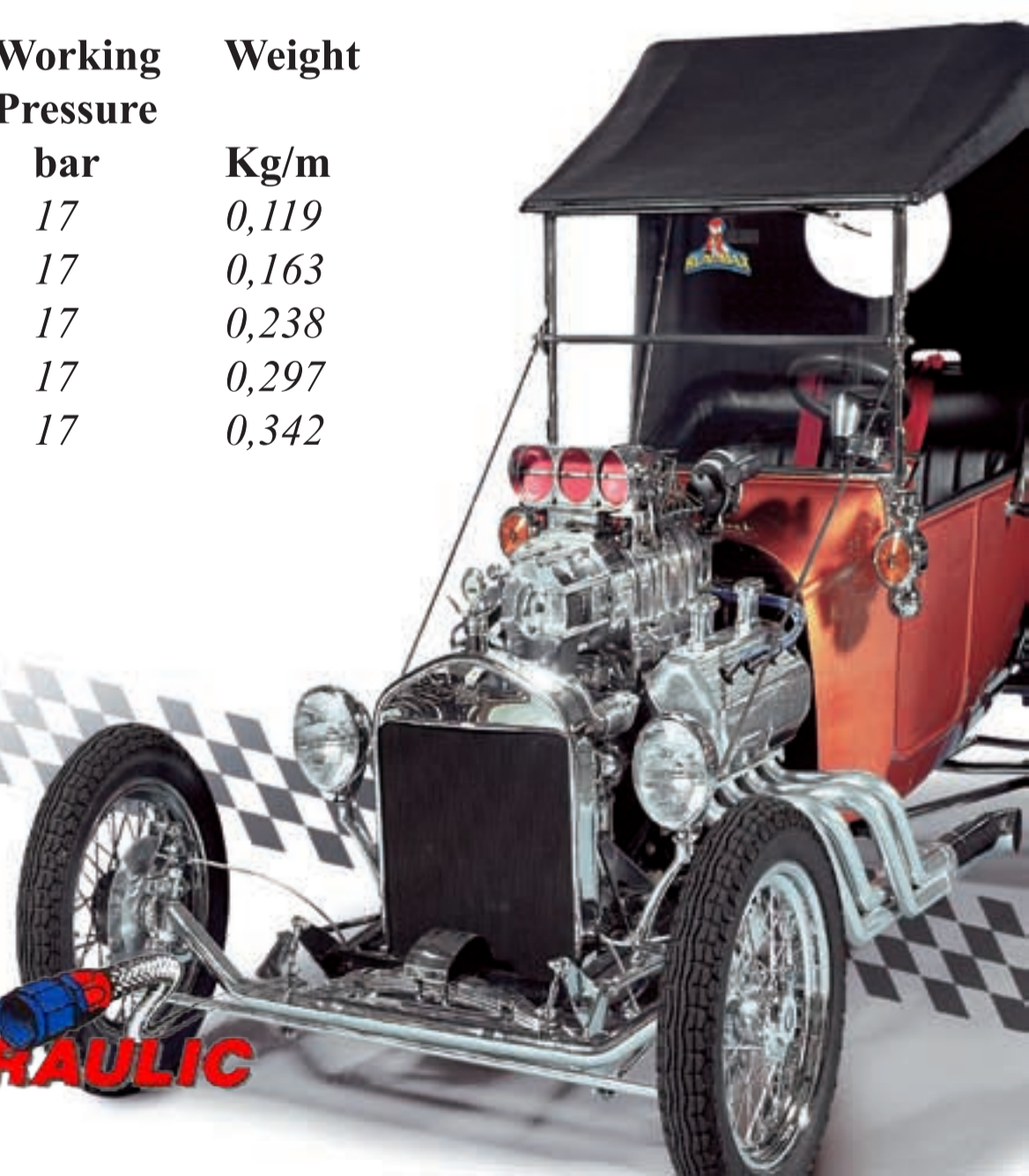





**Straight Female Swivel**

Part no	Hose Size	JIC/UNF Thread
7001-45	-04	7/16 x 14
7001-67	-06	9/16 x 18
7001-09	-08	3/4 x 16
7001-11	-10	7/8 x 14
7001-13	-12	1 1/16 x 12

**45° Female Swept Tube**

Part no	Hose Size	JIC/UNF Thread
7046-45	-04	7/16 x 14
7046-67	-06	9/16 x 18
7046-09	-08	3/4 x 16
7046-11	-10	7/8 x 14
7046-13	-12	1 1/16 x 12

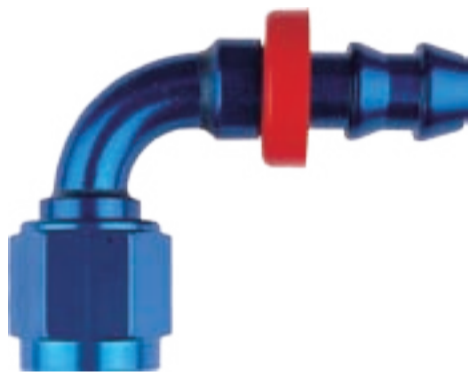

**90° Female Swept Tube**

Part no	Hose Size	JIC/UNF Thread
7091-45	-04	7/16 x 14
7091-67	-06	9/16 x 18
7091-09	-08	3/4 x 16
7091-11	-10	7/8 x 14
7091-13	-12	1 1/16 x 12

**120° Female Swept Tube**

Part no	Hose Size	JIC/UNF Thread
7120-45	-04	7/16 x 14
7120-67	-06	9/16 x 18
7120-09	-08	3/4 x 16
7120-11	-10	7/8 x 14
7120-13	-12	1 1/16 x 12



**150° Female Swept Tube**

Part no	Hose Size	JIC/UNF Thread
7150-45	-04	7/16 x 14
7150-67	-06	9/16 x 18
7150-09	-08	3/4 x 16
7150-11	-10	7/8 x 14
7150-13	-12	1 1/16 x 12

**180° Female Swept Tube**

Part no	Hose Size	JIC/UNF Thread
7180-45	-04	7/16 x 14
7180-67	-06	9/16 x 18
7180-09	-08	3/4 x 16
7180-11	-10	7/8 x 14
7180-13	-12	1 1/16 x 12



*Convolutated light weight ptfe steel/nomex braided*

*Hose "top of the line" the best you can buy today*

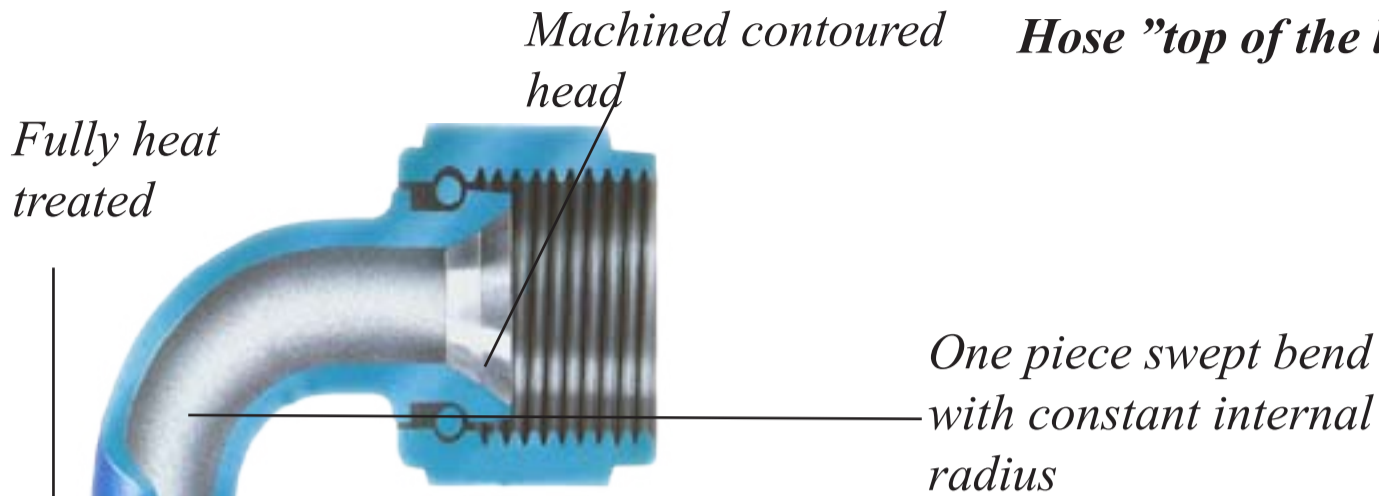

**Stainless Steel Braid**  
Temp Range -54°C to +204°C

Part no	Nom Hose Size	Bore Size mm	Braid O/D mm	Bend Radius mm	Working Pressure bar	Weight Kg/m
AR-06-S	3/8	9.14	13.71	25.4	34.50	0.16
AR-08-S	1/2	10.92	15.74	38.1	34.50	0.19
AR-10-S	5/8	13.71	19.05	50.8	34.50	0.27
AR-12-S	3/4	16.76	22.35	63.5	34,50	0.32
AR-16-S	1	22.1	27.43	88.9	34,50	0.39

**Nomex Braid**  
Temp Range -54°C to +150°C

Part no	Nom Hose Size	Bore Size mm	Braid O/D mm	Bend Radius mm	Working Pressure bar	Weight Kg/m
AR-06-N	3/8	9.14	13.71	25.4	17.25	0.09
AR-08-N	1/2	10.92	15.74	38.1	17.25	0.12
AR-10-N	5/8	13.71	19.05	50.8	17.25	0.19
AR-12-N	3/4	16.76	22.35	63.5	17.25	0.20
AR-16-N	1	22.1	27.43	88.9	17.25	0.25

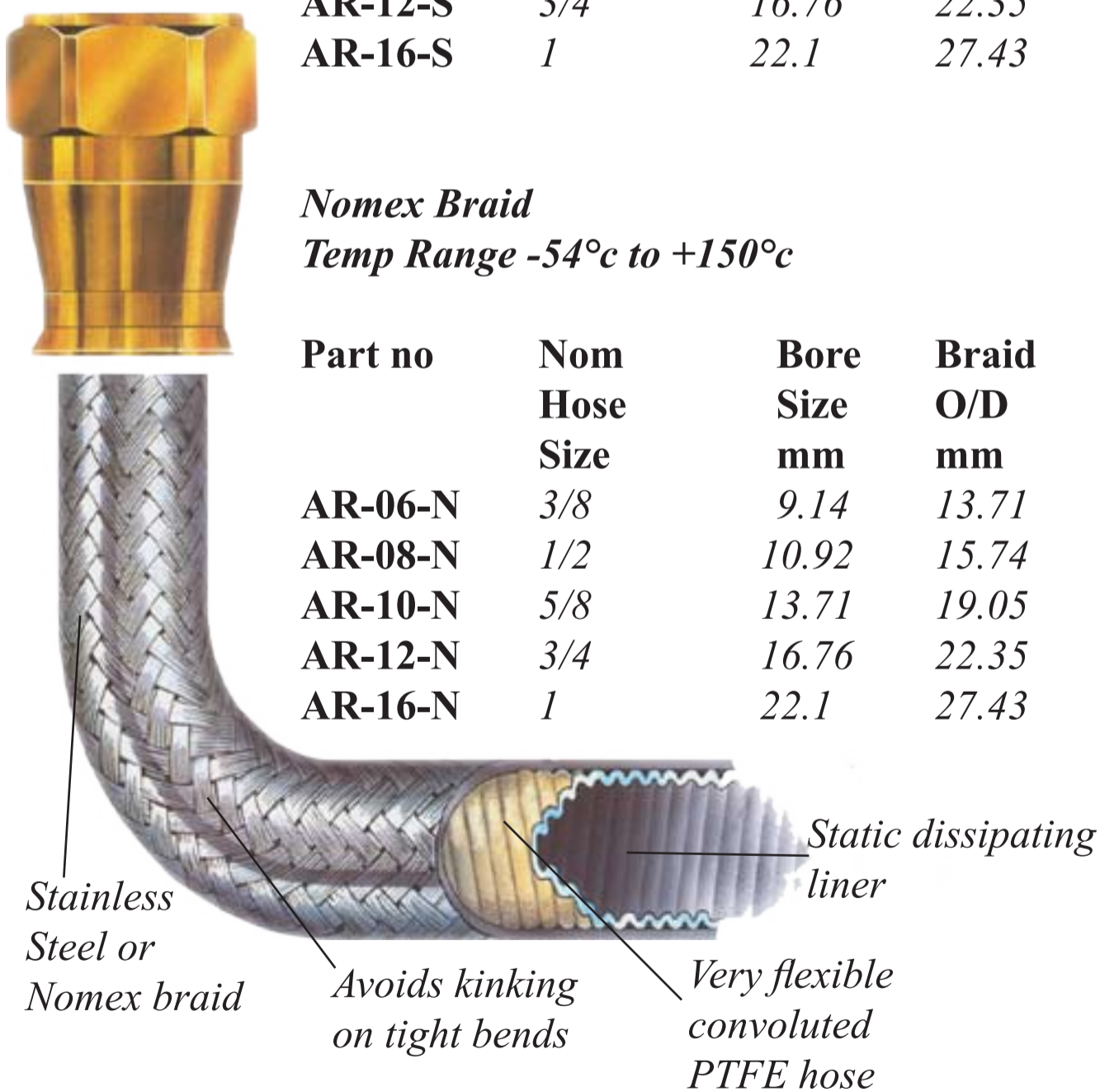



# ProGold Assembly

## Assembly Procedure for ProGold "AR" Reusable Fittings

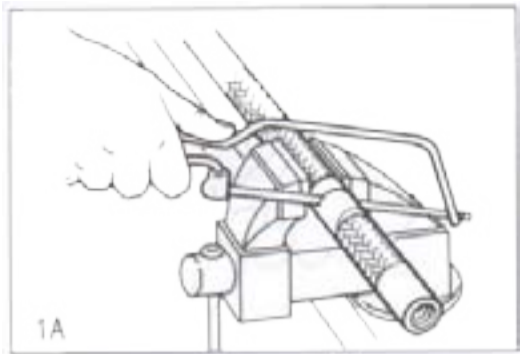

**Metallic Braid:** To minimise braid flare wrap the area of the hose to be cut with masking tape. Cut the hose with a suitable fine toothed hack saw blade. Remove the tape before next step.



**Non-metallic Braid:** Wrap PTFE (teflon) thread tape on area to be cut. DO NOT use adhesive tape of any type. Cut the hose with a suitable sharp knife then carefully remove the tape.

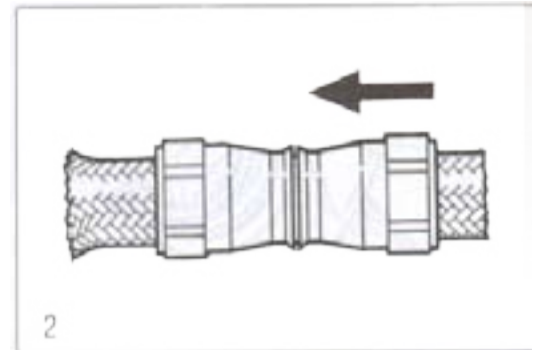

Braid tends to flare more at one end than the other. Assemble both sockets to back from the less flared end.

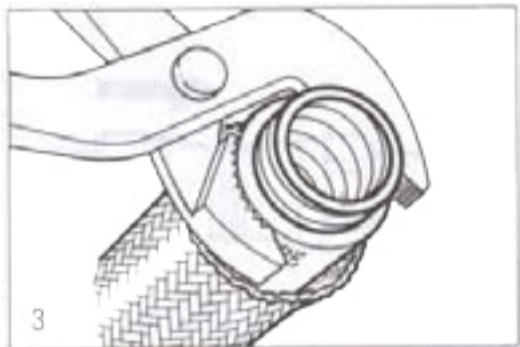

Screw the olive onto the hose until the hose protrudes through the olive. Don't cross thread or force the olive. Make sure the braid goes over the olive.

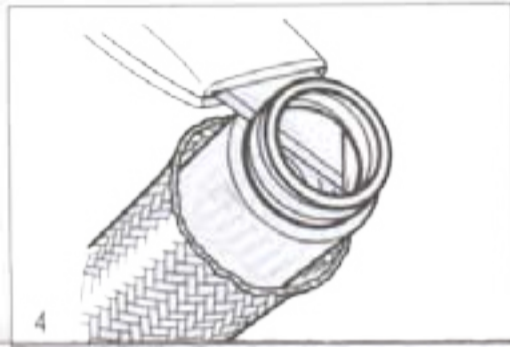

Trim the hose back to be flush or a maximum of 1mm proud of the olive.

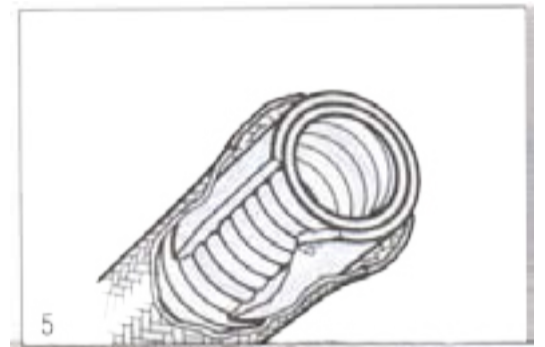

Ensure the hose is cut cleanly and square.

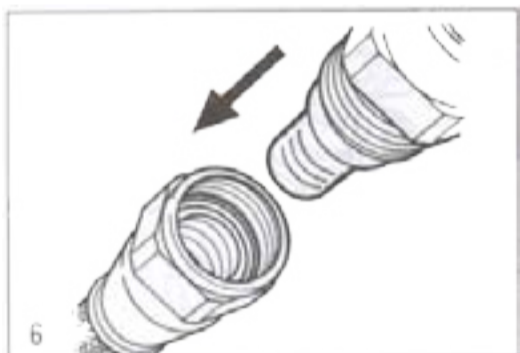

Pull the sockets up over the olives. Lubricate the fitting thread with a light oil. Insert the tail into the hose. Engage the fitting and socket threads. Screw together as far as possible by hand.

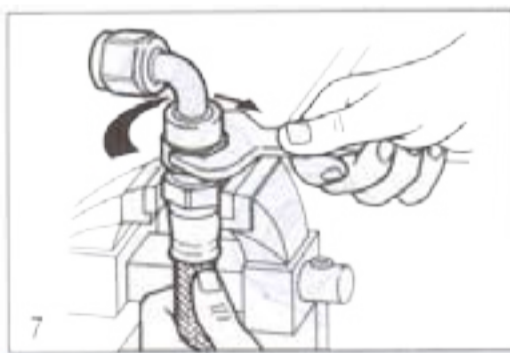

Lightly grip the socket in a set of vice jaws and fully tighten the fitting. (see the picture).

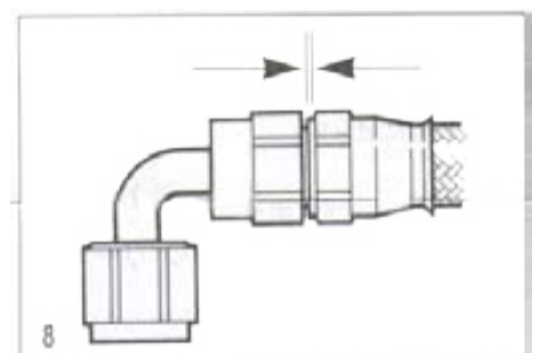

**Metallic Braid:** Socket should be no more than 1mm away from the fitting face.  
**Non-Metallic Braid:** Socket should be touching the fitting face.

Clean the assembly fittings and pressure test the assembly to twice the system working pressure.

**NEVER** Loosen fittings once assembled to achieve the desired orientation.  
**ALWAYS** Use a new olive when reusing an end fitting.  
**IF IN DOUBT** Consult Icore or Your nearest stockist.



**Straight Female Swivel**

Part no	Hose Size	JIC/UNF Thread
AR-06-F3	-06	9/16 x 18
AR-08-F3	-08	3/4 x 16
AR-10-F3	-10	7/8 x 14
AR-12-F3	-12	1 1/16 x 12
AR-16-F3	-16	1 5/16 x 12



**45° Female Swept Tube**

Part no	Hose Size	JIC/UNF Thread
AR-06-G3	-06	9/16 x 18
AR-08-G3	-08	3/4 x 16
AR-10-G3	-10	7/8 x 14
AR-12-G3	-12	1 1/16 x 12
AR-16-G3	-16	1 5/16 x 12



**90° Female Swept Tube**

Part no	Hose Size	JIC/UNF Thread
AR-06-H3	-06	9/16 x 18
AR-08-H3	-08	3/4 x 16
AR-10-H3	-10	7/8 x 14
AR-12-H3	-12	1 1/16 x 12
AR-16-H3	-16	1 5/16 x 12



**120° Female Swept Tube**

Part no	Hose Size	JIC/UNF Thread
AR-06-P3	-06	9/16 x 18
AR-08-P3	-08	3/4 x 16
AR-10-P3	-10	7/8 x 14
AR-12-P3	-12	1 1/16 x 12
AR-16-P3	-16	1 5/16 x 12



**150° Female Swept Tube**

Part no	Hose Size	JIC/UNF Thread
AR-06-R3	-06	9/16 x 18
AR-08-R3	-08	3/4 x 16
AR-10-R3	-10	7/8 x 14
AR-12-R3	-12	1 1/16 x 12
AR-16-R3	-16	1 5/16 x 12



**180° Female Swept Tube**

Part no	Hose Size	JIC/UNF Thread
AR-06-S3	-06	9/16 x 18
AR-08-S3	-08	3/4 x 16
AR-10-S3	-10	7/8 x 14
AR-12-S3	-12	1 1/16 x 12
AR-16-S3	-16	1 5/16 x 12





**45° Female Swept Double swivel Tube**

**90° Female Swept Double swivel Tube**

Part no	Hose Size	JIC/UNF Thread
AR-06-G3-DS	-06	9/16 x 18
AR-08-G3-DS	-08	3/4 x 16
AR-10-G3-DS	-10	7/8 x 14
AR-12-G3-DS	-12	1 1/16 x 12
AR-16-G3-DS	-16	1 5/16 x 12

Part no	Hose Size	JIC/UNF Thread
AR-06-H3-DS	-06	9/16 x 18
AR-08-H3-DS	-08	3/4 x 16
AR-10-H3-DS	-10	7/8 x 14
AR-12-H3-DS	-12	1 1/16 x 12
AR-16-H3-DS	-16	1 5/16 x 12



**120° Female Swept Double swivel Tube**

**150° Female Swept Double swivel Tube**

Part no	Hose Size	JIC/UNF Thread
AR-06-P3-DS	-06	9/16 x 18
AR-08-P3-DS	-08	3/4 x 16
AR-10-P3-DS	-10	7/8 x 14
AR-12-P3-DS	-12	1 1/16 x 12
AR-16-P3-DS	-16	1 5/16 x 12

Part no	Hose Size	JIC/UNF Thread
AR-06-R3-DS	-06	9/16 x 18
AR-08-R3-DS	-08	3/4 x 16
AR-10-R3-DS	-10	7/8 x 14
AR-12-R3-DS	-12	1 1/16 x 12
AR-16-R3-DS	-16	1 5/16 x 12



**180° Female Swept Double swivel Tube**

Part no	Hose Size	JIC/UNF Thread
AR-06-S3-DS	-06	9/16 x 18
AR-08-S3-DS	-08	3/4 x 16
AR-10-S3-DS	-10	7/8 x 14
AR-12-S3-DS	-12	1 1/16 x 12
AR-16-S3-DS	-16	1 5/16 x 12



**Straight Female Metric**

Part no	Hose Size	Thread
AR-06-ST-M12	-06	M12 X 1,5
AR-06-ST-M14	-06	M14 X 1,5
AR-06-ST-M16	-06	M16 X 1,5
AR-08-ST-M18	-08	M18 X 1,5
AR-10-ST-M22	-10	M22 X 1,5



**45° Swept Female Swivel Metric**

Part no	Hose Size	Thread
AR-06-45-M12	-06	M12 x 1,5
AR-06-45-M14	-06	M14 x 1,5
AR-06-45-M16	-06	M16 x 1,5
AR-06-45-M18	-08	M18 x 1,5
AR-06-45-M22	-10	M22 x 1,5



**Socket**

Part no
AR-S-06
AR-S-08
AR-S-10
AR-S-12
AR-S-16



**90° Swept Female Swivel Metric**

Part no	Hose Size	Thread
AR-06-90-M12	-06	M12 x 1,5
AR-06-90-M14	-06	M14 x 1,5
AR-06-90-M16	-06	M16 x 1,5
AR-06-90-M18	-08	M18 x 1,5
AR-06-90-M22	-10	M22 x 1,5

**NOTE:**  
A new Olive **MUST** always be fitted when reusing an end fitting.



**Olive**

Part no
AR-O-06
AR-O-08
AR-O-10
AR-O-12
AR-O-16



**Banjo with Banjo Bolt**

Part no	Hose Size	Bolt Thread
AR-06-BJ-01	-06	9/16 x 24
AR-06-BJ-02	-06	M12 x 1,25
AR-06-BJ-03	-06	M12 x 1,5
AR-06-BJ-04	-06	M12 x 1,5



**Banjo with Banjo Bolt**

Part no	Hose Size	Bolt Thread
AR-06-DBJ-01	-06	9/16 x 24
AR-06-DBJ-02	-06	M12 x 1,25
AR-06-DBJ-03	-06	M12 x 1,5
AR-06-DBJ-04	-06	M12 x 1,5



# Aluminium adapters



**Straight JIC (AN) x NPT**

Part no	AN-Dim	Thread
9816-03	-03	1/8
9816-04	-04	1/8
9816-44	-04	1/4
9816-62	-06	1/8
9816-06	-06	1/4
9816-66	-06	3/8
9816-68	-06	1/2
9816-07	-08	1/4
9816-08	-08	3/8
9816-88	-08	1/2
9816-11	-10	3/8
9816-10	-10	1/2
9816-09	-10	3/4
9816-12	-12	3/4
9816-13	-12	1/2
9816-15	-16	3/4
9816-16	-16	1



**45° JIC (AN) x NPT**

Part no	AN-Dim	Thread
9823-03	-03	1/8
9823-04	-04	1/8
9823-44	-04	1/4
9823-62	-06	1/8
9823-06	-06	1/4
9823-66	-06	3/8
9823-68	-06	1/2
9823-07	-08	1/4
9823-08	-08	3/8
9823-88	-08	1/2
9823-11	-10	3/8
9823-10	-10	1/2
9823-09	-10	3/4
9823-12	-12	3/4
9823-13	-12	1/2
9823-16	-16	1



**90° JIC (AN) x NPT**

Part no	AN-Dim	Thread
9822-03	-03	1/8
9822-04	-04	1/8
9822-44	-04	1/4
9822-62	-06	1/8
9822-06	-06	1/4
9822-66	-06	3/8
9822-68	-06	1/2
9822-07	-08	1/4
9822-08	-08	3/8
9822-88	-08	1/2
9822-11	-10	3/8
9822-10	-10	1/2
9822-09	-10	3/4
9822-12	-12	3/4
9822-13	-12	1/2
9822-15	-16	3/4
9822-16	-16	1



**Straight Swivel on JIC (AN) x NPT**

Part no	AN-Dim	Thread
916-03D	-03	1/8
916-04D	-04	1/8
916-44D	-04	1/4
916-62D	-06	1/8
916-06D	-06	1/4
916-66D	-06	3/8
916-07D	-08	1/4
916-08D	-08	3/8
916-88D	-08	1/2
916-11D	-10	3/8
916-10D	-10	1/2
916-12D	-12	3/4
916-13D	-12	1/2

# Aluminium adapters



JIC (AN) x NPT On Side

Part no	AN-Dim	Thread
9825-03	-03	1/8
9825-04	-04	1/8
9825-06	-06	1/4
9825-08	-08	3/8
9825-10	-10	1/2
9825-12	-12	3/4



T JIC (AN) x NPT On Run

Part no	AN-Dim	Thread
9826-03	-03	1/8
9826-04	-04	1/8
9826-06	-06	1/4
9826-08	-08	3/8
9826-10	-10	1/2
9826-12	-12	3/4



90° JIC (AN)

Part no	AN-Dim
9821-03	-03
9821-04	-04
9821-06	-06
9821-08	-08
9821-10	-10
9821-12	-12
9821-16	-16



T JIC (AN)

Part no	AN-Dim
9824-03	-03
9824-04	-04
9824-06	-06
9824-08	-08
9824-10	-10
9824-12	-12
9824-16	-16



JIC (AN) Union Reducer

Part no	AN-Dim	AN-Dim
9919-02	-03	-04
9919-03	-05	-04
9919-05	-06	-03
9919-06	-06	-04
9919-07	-06	-05
9919-12	-08	-06
9919-14	-10	-06
9919-15	-10	-08
9919-18	-12	-06
9919-19	-12	-08
9919-20	-12	-10
9919-22	-16	-10
9919-23	-16	-12

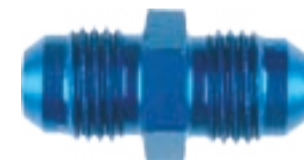

JIC (AN) Union Male

Part no	AN-Dim
9815-03	-03
9815-04	-04
9815-06	-06
9815-08	-08
9815-10	-10
9815-12	-12
9815-16	-16

# Aluminium adapters



45° JIC (AN) Bulkhead

Part no	AN-Dim
9837-03	-03
9837-04	-04
9837-06	-06
9837-08	-08
9837-10	-10
9837-12	-12



90° JIC (AN) Bulkhead

Part no	AN-Dim
9833-03	-03
9833-04	-04
9833-06	-06
9833-08	-08
9833-10	-10
9833-12	-12
9833-16	-16



T JIC (AN) Bulkhead On Run

Part no	AN-Dim
9804-03	-03
9804-04	-04
9804-06	-06
9804-08	-08



T JIC (AN) Bulkhead On Side

Part no	AN-Dim
9834-03	-03
9834-04	-04
9834-06	-06
9834-08	-08
9834-10	-10
9834-12	-12



JIC (AN) Bulkhead

Part no	AN-Dim
9832-03	-03
9832-04	-04
9832-06	-06
9832-08	-08
9832-10	-10
9832-12	-12
9832-16	-16



Lock Nut

Part no	AN-Dim
9924-03	-03
9924-04	-04
9924-06	-06
9924-08	-08
9924-10	-10
9924-12	-12
9924-16	-16



# Aluminium adapters



45° Female AN swivel to male AN

Part no	AN-Dim
9241-03	-03
9241-04	-04
9241-06	-06
9241-08	-08
9241-10	-10
9241-12	-12



90° Female AN swivel to male AN

Part no	AN-Dim
9211-03	-03
9211-04	-04
9211-06	-06
9211-08	-08
9211-10	-10
9211-12	-12



45° Female AN to female AN

Part no	AN-Dim
9391-03	-03
9391-04	-04
9391-06	-06
9391-08	-08
9391-10	-10
9391-12	-12



90° Female AN to female AN

Part no	AN-Dim
9341-03	-03
9341-04	-04
9341-06	-06
9341-08	-08
9341-10	-10
9341-12	-12



AN Tee Female swivel on Run

Part no	AN-Dim
9261-03	-03
9261-04	-04
9261-06	-06
9261-08	-08
9261-10	-10
9261-12	-12



AN Tee Female swivel on Side

Part no	AN-Dim
9251-03	-03
9251-04	-04
9251-06	-06
9251-08	-08
9251-10	-10
9251-12	-12



# Aluminium adapters



**Straight Female AN Swivel Coupling**

Part no	AN-Dim	AN-Dim
9151-03	-03	-03
9151-04	-04	-04
9151-06	-06	-06
9151-08	-08	-06
9151-08	-08	-08
9151-10	-10	-10
9151-12	-12	-12
9151-16	-16	-16



**90° Male AN to Male Swivel NPT**

Part no	AN-Dim	Thread
9221-03	-03	1/8
9221-04	-04	1/8
9221-44	-04	1/4
9221-06	-06	1/4
9221-62	-06	1/8
9221-66	-06	3/8
9221-07	-08	1/4
9221-08	-08	3/8
9221-88	-08	1/2
9221-10	-10	1/2
9221-11	-10	3/8



**AN Male Weld Adapter**

Part no	AN-Dim
9971-04	-04
9971-06	-06
9971-08	-08
9971-10	-10
9971-12	-12
9971-16	-16



**AN Port Adapter ("O" Ring Seal)**

Part no	AN-Dim	Thread
9850-64	-06	7/16-20
9850-65	-06	1/2-20
9850-06	-06	9/16-18
9850-68	-06	3/4-16
9850-86	-08	9/16-18
9850-08	-08	3/4-16
9850-81	-08	7/8-14
9850-09	-10	3/4-16
9850-10	-10	7/8-14
9850-11	-10	1 1/16-12
9850-13	-12	7/8-14
9850-12	-12	1 1/16-12



**Port Plug ("O" Ring Seal)**

Part no	Thread
9814-03	3/8-24
9814-04	7/16-20
9814-06	9/16-18
9814-08	3/4-16
9814-10	7/8-14
9814-12	1 1/16-12
9814-16	1 5/16-12

# Aluminium adapters



AN Reducer ("O" Ring Seal)

Part no	AN-Dim Inv.	AN-Dim Unv.
9894-43	-04	-03
9894-64	-06	-04
9894-86	-08	-06
9894-04	-10	-08
9894-09	-12	-08
9894-10	-12	-10
9894-11	-16	-12



Flare Reducer

Part no	AN-Dim Inv.	AN-Dim Inv.
98920-64	-06	-04
98920-84	-08	-04
98920-86	-08	-06
98921-04	-10	-04
98921-06	-10	-06
98921-08	-10	-08
98921-26	-12	-06
98921-28	-12	-08
98921-20	-12	-10
98921-60	-16	-10
98921-62	-16	-12



Carburetor / Power Steering  
Fuel Pump / Fuel Injection Adapters

Part no	AN-Dim	Thread	Typical Application
9919-41	-06	5/8-20	Carter / Edelbrock
9919-42	-06	9/16-24	Single Inlet Holley
9919-43	-06	7/8-20	Dual Feed Holley
9919-44	-06	M12 x 1,5	Weber
9919-45	-06	M12 x 1,25	Dellorto / Solex / Mikuni
9919-46	-06	1/2-20	Power Steering / Fuel Pump - 5/16 Tube Inverted Flare
9919-47	-06	5/8-18	Power Steering / Fuel Pump - 3/8 Tube Inverted Flare
9919-48	-08	7/8-20	Dual Feed Holley
9919-49	-06	7/8-20	Rochester
9919-50	-06	11/16-18	Power Steering Inverted Flare
9919-51	-06	7mm Banjo bolt	Dellorto
9919-52	-06	1"-20	Rochester 75-
9919-53	-06	M10 x 1	Weber
9919-54	-06	M14 x 1,5	Power Steering / Fuel Injection - O-Ring Seal
9919-55	-06	M16 x 1,5	Power Steering / Fuel Injection - O-Ring Seal
9919-56	-06	M18 x 1,5	Power Steering - O-Ring Seal
9894DBH	-06	M14 x 1,5	Fuel Injection Fem. O-Ring Seal
9894DBJ	-06	M16 x 1,5	Fuel Injection Fem. O-Ring Seal

# Aluminium adapters



AN Cap

Part no	AN-Dim
9929-03	-03
9929-04	-04
9929-06	-06
9929-08	-08
9929-10	-10
9929-12	-12
9929-16	-16



AN Plug

Part no	AN-Dim
9806-03	-03
9806-04	-04
9806-06	-06
9806-08	-08
9806-10	-10
9806-12	-12
9806-16	-16



Tube Nut

Part no	AN-Dim
9818-03	-03
9818-04	-04
9818-06	-06
9818-08	-08
9818-10	-10
9818-12	-12
9818-16	-16



Tube Sleeve

Part no	AN-Dim
9819-03	-03
9819-04	-04
9819-06	-06
9819-08	-08
9819-10	-10
9819-12	-12
9819-16	-16



Banjo Adapter

Part no	AN-Dim	Hole Size
776-04M10	-04	M10
776-06D	-06	9/16
776-06M12	-06	M12
776-06M14	-06	M14
776-06M16	-06	M16
776-08M16	-08	M16



# Alu Adapter NPT



Female Coupling

Part no	Thread
9910-01	1/8
9910-02	1/4
9910-03	3/8
9910-04	1/2
9910-06	3/4



Male Nipple

Part no	Thread
9911-01	1/8
9911-02	1/4
9911-03	3/8
9911-04	1/2
9911-06	3/4



90° Elbow Internal/External Pipe Thread

Part no	Pipe Thread
9914-01	1/8
9914-02	1/4
9914-03	3/8



45° Elbow Internal/External Pipe Thread

Part no	Pipe Thread
9915-01	1/8
9915-02	1/4
9915-03	3/8



90° Elbow Internal Pipe Thread

Part no	Pipe Thread
9916-01	1/8
9916-02	1/4
9916-03	3/8



Tee Internal Pipe Thread

Part no	Pipe Thread
9917-01	1/8
9917-02	1/4
9917-03	3/8



Reducer Pipe Bushing

Part no	Female. Thread	Male. Thread
9912-01	1/8	1/4
9912-02	1/4	3/8
9912-03	1/8	3/8
9912-04	3/8	1/2
9912-05	1/4	1/2
9912-06	1/8	1/2
9912-070	1/2	3/4
9912-08	3/8	3/4
9912-09	1/4	3/4
9912-10	3/4	1
9912-11	1/2	1
9912-12	3/8	1
9912-13	3/4	1 1/4



Plug Socket Head

Part no	Thread
9932-01	1/16
9932-02	1/8
9932-03	1/4
9932-04	3/8
9932-05	1/2
9932-06	3/4

## Alu Adapter JIC/mm



### JIC / Metric Conv.

Part no	AN-Dim	Thread
305-03-31D	-03	M10 x 1
305-04-31D	-04	M10 x 1
305-06-31D	-06	M10 x 1
305-06-42D	-06	M12 x 1,25
305-06-55D	-06	M14 x 1,5
305-06-65D	-06	M16 x 1,5
305-08-31D	-08	M10 x 1
305-08-45D	-08	M12 x 1,5
305-08-55D	-08	M14 x 1,5
305-08-65D	-08	M16 x 1,5
305-12-09D	-12	M20 x 1,5

### JIC / Metric Conc.

Part no	AN-Dim	Thread
306-03-32D	-03	M10 x 1,25
306-03-41D	-03	M12 x 1
306-03-45D	-03	M12 x 1,5
306-03-55D	-03	M14 x 1,5
306-04-31D	-04	M10 x 1
306-04-32D	-04	M10 x 1,25
306-04-41D	-04	M12 x 1
306-04-55D	-04	M14 x 1,5
306-04-65D	-04	M16 x 1,5
306-06-32D	-06	M10 x 1,25
306-06-41D	-06	M12 x 1
306-06-52D	-06	M14 x 1,25
306-06-55D	-06	M14 x 1,5
306-06-65D	-06	M16 x 1,5
306-06-08D	-06	M18 x 1,5
306-06-09D	-06	M20 x 1,5
306-06-10D	-06	M22 x 1,5
306-08-45D	-08	M12 x 1,5
306-08-65D	-08	M16 x 1,5
306-08-08D	-08	M18 x 1,5
306-08-09D	-08	M20 x 1,5
306-08-10D	-08	M22 x 1,5
306-10-65D	-10	M16 x 1,5
306-10-08D	-10	M18 x 1,5
306-10-09D	-10	M20 x 1,5
306-10-10D	-10	M22 x 1,5
306-10-12D	-10	M26 x 1,5
306-12-08D	-12	M18 x 1,5
306-12-09D	-12	M20 x 1,5
306-12-10D	-12	M22 x 1,5
306-12-12D	-12	M26 x 1,5
306-12-16D	-12	M30 x 1,5
306-20-16D	-20	M30 x 1,5

## Alu Adapter JIC/bsp



### JIC / bsp Conv.

Part no	AN-Dim	Thread
741-03-03D	-03	R 1/8 bsp
741-03-03	-03	R 1/8 bsp
741-04-06D	-06	R 1/4 bsp
741-06-06D	-06	R 3/8 bsp
741-06-08D	-08	R 3/8 bsp
741-06-10D	-10	R 3/8 bsp
741-08-06D	-06	R 1/2 bsp
741-08-08D	-08	R 1/2 bsp
741-08-10D	-10	R 1/2 bsp
741-08-12D	-12	R 1/2 bsp
741-10-10D	-10	R 5/8 bsp
741-10-12D	-12	R 5/8 bsp



# Oil Cooling



Oilcoolers and Filter adapters  
Coolers from **Setrab** for all kind of cooling.  
Power Steering, Engines, Automatic Transmissions and Rear Axles.  
Oil filter adapters and detached filter holders to most common Cars.



# Oil Coolers

**Oil Coolers stored in two Widths:**  
 210mm (Serie 100) Connection thread. M22 x 1,5  
 330mm (Serie 600) Connection thread. M22 x 1,5  
**Other Sizes are available on order**

**Serie 100**  
 Width 210mm  
 Thickness 50mm

Part no	Heiht mm.	Weight Kg	Quantity rows
107M22	50	0,31	7
110M22	74	0,39	10
113M22	98	0,48	13
116M22	122	0,60	16
119M22	146	0,67	19
125M22	194	0,84	25
134M22	266	1,15	34



## Setrab

Pro Line

**Serie 600**  
 Width 330mm  
 Thickness 50mm



Part no	Heiht mm.	Weight Kg	Quantity rows
607M22	50	0,52	7
610M22	74	0,71	10
613M22	98	0,88	13
616M22	122	1,03	16
619M22	146	1,23	19
625M22	194	1,56	25
634M22	266	2,14	34
644M22	346	2,70	44

## Setrab

Pro Line

Appropriate adapter for connecting AN fittings to the cooler



Part no	Thread	AN-Dim
AN6M22	M22	-06
AN8M22	M22	-08
AN10M22	M22	-10
AN12M22	M22	-12



# *Oil Filter Adapter*



## **Sandwich Adapter "American Style"**

Allows adaption of oil cooler while mantaining the filter location.  
 The adapter adds 25mm to length of the filter  
 (except 504 & 513 47mm) connection thread is 3/8NPT

Part no	Oil Filter Thread	Typical Applications
509	22mm x 1,5	Most Honda Some Ford
510	3/4-16	Most Ford, Chrysler, Toyota, Nissan & VW
511	M18 x 1,5	Some GM Engine with "Spin On" Filter
512	13/16-16	Most GM and American motors except Chevy V-8
513	13/16-16	Most Chevy V-8 with "Spin On" filter. All V-8 -96
514	M20 x 1,5	Most Honda and some Ford



## **Sandwich Adapter "American Style" with Oil Thermostat**

Facilitates a quick oil warm up.  
 Opens at 70°C full open at 80°C Connection thread 7/8-14 ("O" Ring sealed)

Part no	Oil Filter Thread	Typical Applications
502	3/4-16	Most Ford, Chrysler, Toyota, Nissan & VW
503	13/16-16	Most GM and American motors except Chevy V-8
504	13/16-16	Most Chevy V-8 with "Spin On" filter. All V-8 -96



# Oil Filter Adapter

## Serie K-100



Serie K-100  
Sandwich Adapter  
Required when Pressure and Temp Socket.  
Is missing on you engine.  
Series K-100 Delivered with.  
2 x O-Rings

Part no	Oil Filter Thread	Typical Applications
K100-20	M20 x 1,5	Most Nissan, Mitsubichi, Subaru m.m.
K100-22	M22 x 1,5	Most Honda CRX, m.m.
K100-34	3/4-16	Most VAG, BMW, Volvo, SAAB 4Cyl, m.m

**For Temp and Pressure sending unit adapters Se Table Page.49**

## Serie K-200



Serie K-200  
Inline Adapter  
Required when measuring Temp and Pressure "In Line".  
Serie K-200 Delivered with.  
2 x AN-10 Connections.

Part no	Oil Filter Thread	Typical Applications
K200	X	Most Ford, Chrysler, Toyota, Nissan & VW

**For Temp and Pressure sending unit adapters Se Table Page.49**

## Serie K-300

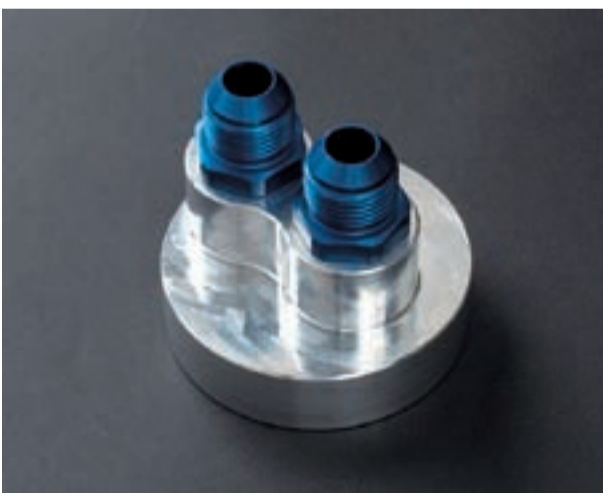

Serie K-300  
Block Of Adapter  
Required when relocating the oil filter, and also when connecting  
oil cooler.  
Serie K-300 Delivered with.  
2 x AN-10 connections and 2 x O-Rings.

Part no	Oil Filter Thread	Typical Applications
K300-20	M20 x 1,5	Most Nissan, Mitsubichi, Subaru m.m.
K300-34	3/4-16	Most VAG, BMW, Volvo, SAAB 4Cyl, m.m

**For Temp and Pressure sending unit adapters Se Table Page.49**



# Oil Filter Adapter

## Serie K-400



Serie K-400  
Sandwich Adapter "European Style"  
Allows adaptation of oil cooler.  
While maintaining the oil filter location  
The adapter adds 30mm to length of the filter  
Serie K-400 Delivered with.  
2 x AN-10 connections and 2 x O-Rings.

Part no	Oil Filter Thread	Typical Applications
K400-20	M20 x 1,5	Most Nissan, Mitsubichi, Subaru m.m.
K400-22	M22 x 1,5	Most Honda CRX, m.m
K400-34	3/4-16	Most VAG, BMW, Volvo, SAAB 4Cyl, m.m

**For Temp and Pressure sending unit adapters Se Table Page.49**

## Serie K-450



Serie K-450  
Sandwich Adapter "European Style"  
Allows adaptation of oil cooler.  
While maintaining the oil filter location  
The adapter adds 30mm to length of the filter  
Also allows Temp and Pressure measuring  
Serie K-450 Delivered with.  
2 x AN-10 connections and 2 x O-Rings.

Part no	Oil Filter Thread	Typical Applications
K450-20	M20 x 1,5	Most Nissan, Mitsubichi, Subaru m.m.
K450-22	M22 x 1,5	Most Honda CRX, m.m
K450-34	3/4-16	Most VAG, BMW, Volvo, SAAB 4Cyl, m.m

**For Temp and Pressure sending unit adapters Se Table Page.49**

# *Oil Filter Adapter*

## Serie K-500



Serie K-500  
Remote Filter Mount.  
Allows Temp and Pressure Measuring.  
Serie K-500 Delivered with.  
2 x AN-10 Connections.

Part no	Oil Filter Thread	Typical Applications
K500	3/4-16	Most Engine

**For Temp and Pressure sending unit adapters See Table Page.49**

## Serie K-600



Serie K-600  
Remote Filter Mount with "built in" Thermostat.  
Allows oil cooler connection.  
Allows Temp and Pressure Measuring.  
Delivered with.  
4 x AN-10 Connections.

Part no	Oil Filter Gänga	Typical Applications
K600	3/4-16	Most Engine

**For Temp and Pressure sending unit adapters See Table Page.49**

# Oil Filter Adapter



## Temp and Pressure sending unit adapters and Plugs

Adapter Nr.	Part no	Thread	Fits Adapter
1	K18	1/8 NPT	K200 , K500 , K600
2	K10M	M10 x 1	K200 , K500 , K600
3	K12M	M12 x 1,25	K200 , K500 , K600
4	K14M	M14 x 1,5	K200 , K500 , K600
5	K16M	M16 x 1,5	K200 , K500 , K600
6	K6001	5/8-18 UNF	K200 , K500 , K600
7	KBM	PLUGG	K200 , K500 , K600
8	K218	1/8 NPT	K100 , K450
9	K210M	M10 x 1	K100 , K450
10	K212M	M12 x 1,25	K100 , K450
11	K214M	M14 x 1,5	K100 , K450
12	K216M	M16 x 1,5	K100 , K450
13	K26001	5/8 x 18 UNF	K100 , K450
14	K2BM	PLUGG	K100 , K450
15	K067814	AN6 x 7/8-14	Passar hela K-Serien
16	K087814	AN8 x 7/8-14	Passar hela K-Serien
17	K107814	AN10 x 7/8-14	Passar hela K-Serien
18	K127814	AN12 x 7/8-14	Passar hela K-Serien
19	K167814	AN16 x 7/8-14	Passar hela K-Serien
20	K108D	AN10 x 7/8-14	Passar hela K-Serien



K418 K420 K422 K434 K4316



K2178 K320 K334

## Filter Thread

Part no	Filter Thread	Fits Adapter
K418	M18 x 1,5	K100 , K400 , K450
K420	M20 x 1,5	K100 , K400 , K450
K422	M22 x 1,5	K100 , K400 , K450
K434	3/4-16	K100 , K400 , K450
K4316	13/16-16	K100 , K400 , K450
K320	M20 x 1,5	K300
K334	3/4-16	K300
K2178	3/4-16	K500 , K600



# Fuel System

Fuel Safe Safety Tanks  
Necessary for racing with highest secure.





**Filler caps "Aircraft Style" Aluminium available in three sizes.**  
 With or without lock with or without integral forged hose connecting neck



**A26**



**A36N**



**A48**

**N in part.no. stands for "Neck"**

Part no	OD	Bolt circle Dia	Assembly Holes	Weight Gr	Lock	Hose Id
A26S	80	65,5	6 x 4mm	100	N	
A26NS	80	65,5	6 x 4mm	155	N	50mm / 58mm
A36S	94,25	76,2	6 x 5mm	176	N	
A36NS	94,25	76,2	6 x 5mm	248	N	50mm / 58mm
A36L	94,25	76,2	6 x 5mm	176	J	
A36NL	94,25	76,2	6 x 5mm	248	J	50mm / 58mm
A48L	120	101,6	8 x 5mm	230	J	
A48S	120	101,6	8 x 5mm	230	N	

**Fixing Rings, Hose Connectors for the Filler Caps above.**  
 The Fixing Ring makes it easier to mount a Filler Caps on top of a Tank.



**CN4850**

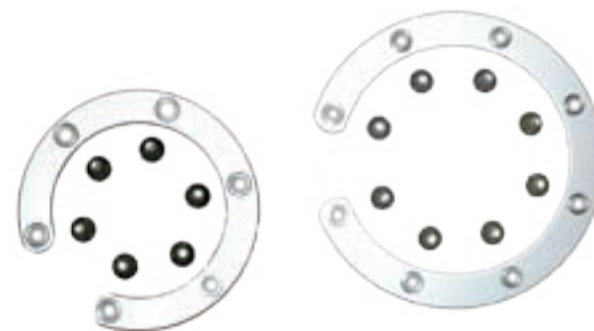

Part no	Bolt circle Dia	Assembly Holes	Fill Neck	Hose Id
FR26	65,5	6 x 4mm		
FR36	76,2	6 x 5mm		
FR48	101,6	8 x 5mm		
CN4850	101,6	8 x 5mm	for A48	50mm





**A "High Capacity" Fuel Filter for Carburetors and Injection**  
 Interchangeable Filterelement 25microns inside aluminium tube, selective AN connection



### Fuel Filter High Flow

#### Filter

Part no	AN-Dim.	Female. Thread	Length	Dia. ø
230900	X	M22 x 1,5	150mm	55mm
230910	X	M22 x 1,5	120mm	55mm

#### Filter Adapters

Part no	AN-Dim.	Male.Thread
AN6M22	-06	M22 x 1,5
AN8M22	-08	M22 x 1,5
AN10M22	-10	M22 x 1,5
AN12M22	-12	M22 x 1,5

#### Filter Element

Part no	Fits Filter
230901	230900
230911	230910





### Fuel / Oil Filters "In Line"

"Pre" Filters easily disassembled for inspection and cleaning.

Part no Fuel	AN-Dim.	Part no Oil
230204	-04	230304
230206	-06	230306
230208	-08	230308
230210	-10	230310
230212	-12	230312
230216	-16	230316



### Fuel Filter "In Line"

Sintered Bronz / 35micron.

Easily disassembled for inspection and cleaning.

Part no	AN-Dim.
230103	5/16 Hose Barb
230106	-06
230108	-08
230107	Filter Element



### Check Valves "In Line" One Way (Non Return)

To keep fuel pressure or fuel level in fuel system after the engine is shut off

Part no	AN-Dim.
251004	-04
251006	-06
251008	-08
251010	-10
251012	-12
251016	-16



### Fuel shut off valve

Part no	AN-Dim.	Female Thread
230502	-06	3/8 NPT
230503	-08	3/8 NPT
230505	-10	1/2 NPT





## Gauges, Pumps, Regulators and Pipes

**Note: Don't use Rubber Hose for fuel in driving compartment**

Use Stainless / Aluminium tubing or Teflon Hose



### Fule Pressure Gauge

0 - 15 psi Male Thread.1/8 NPT

OD. 42mm Deep 24mm (40mm inkl.thread back)

NOTE! Not always exactly as on picture

Part no	Male.Thread	YD. ø
100195	1/8 NPT	42mm
100189	1/8 NPT (Oil Filled)	42mm



### Fuel Pressure Regulator

For Injection and Carburetors

Follow Fuel pressure linear

Part no	AN-Dim.
K1406CA	-06
K1408CA	-08



### Fuel pump

Part no	Female. Thread
230800	M18 x 1,5



### Quick Disconnect Fitting Aluminium

Part no	AN-Dim.
240106	-06
240108	-08
240110	-10
240112	-12

### Stainless Tubing

Se Page 20



Adapter to make AN connection for fuel pump above.

Part no	Thread	AN-Dim
AN6M18	M18 x 1,5	-06
AN8M18	M18 x 1,5	-08
AN10M18	M18 x 1,5	-10

### Aluminium Tubing

Easy to bend, can connect direct to Hose Connectors

Typ 3601-xx, or flare then use Nut (9818-xx and Tube Sleeve (9819-xx).

Delivered in 3meter Lenght.

Part no	Male.Thread	AN-Dim.
100031	1/4	-04
100034	3/8	-06
100037	1/2	-08



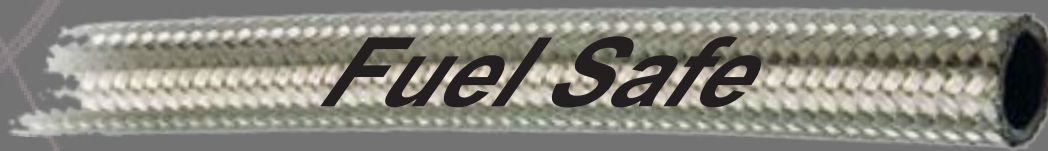

Fuel Bladders in any size

Even complex bladders that leave other manufacturers scratching their heads are never a problem at Fuel Safe.

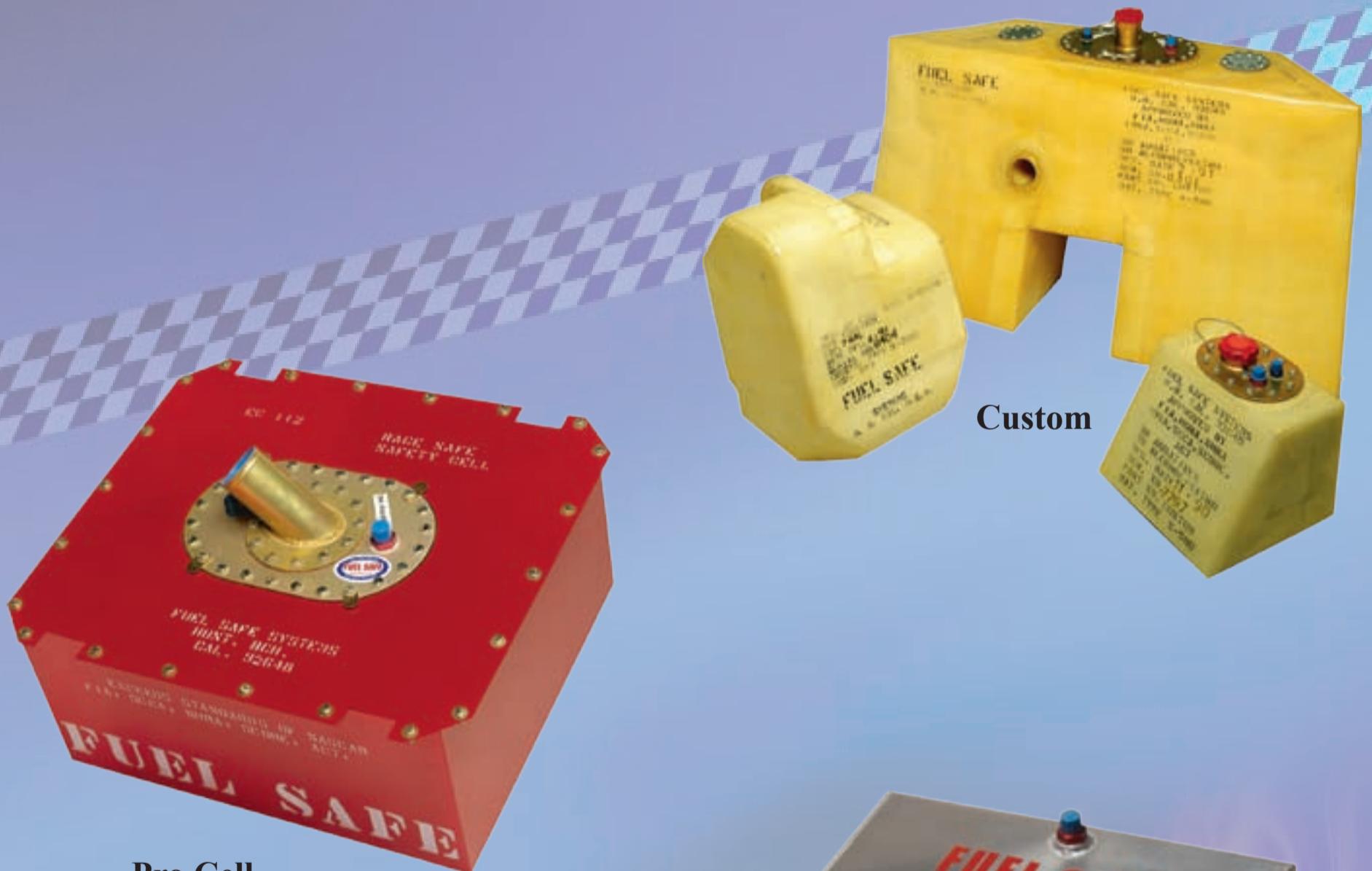

Pro Cell

Custom



Street / Strip







**PRO-CELL**  
**Top of the line Fuel Cell**  
**FIA-SCCA-USRRC-NHRA-ACT-SCORE-ASA-NASCAR Approved**  
**Note! Not for Nitro & Alcohol use!**



**Pro Cell**

Part no	Volume	Length	Width	Height
PC105	5 Gal.	13 1/2 in.	13 1/2 in.	8 1/4 in.
PC108A	8 Gal.	20 1/8 in.	8 5/8 in.	12 1/8 in.
PC108B	8 Gal.	20 1/8 in.	12 1/8 in.	8 5/8 in.
PC109*	9 Gal.	20 1/8 in.	12 1/8 in.	8 5/8 in.
PC110	10 Gal.	25 5/8 in.	10 1/8 in.	10 1/8 in.
PC112	12 Gal.	20 1/8 in.	17 1/8 in.	9 1/8 in.
PC115A-M****	15 Gal.	23 3/4 in.	17 5/8 in.	10 in.
PC115	15 Gal.	24 5/8 in.	17 1/8 in.	9 1/8 in.
PC117	17 Gal.	20 1/8 in.	17 1/8 in.	12 3/4 in.
PC118A	18 Gal.	28 in.	17 1/8 in.	9 7/8 in.
PC118B	18 Gal.	33 1/2 in.	20 in.	6 1/2 in.
PC118C	18 Gal.	33 1/2 in.	20 in.	6 1/2 in.
PC122A	22 Gal.	34 in.	17 1/2 in.	9 1/2 in.
PC122B	22 Gal.	25 in.	16 3/4 in.	13 5/8 in.
PC122C	22 Gal.	25 3/4 in.	25 3/4 in.	8 1/2 in.
PC122D***	22 Gal.	32 5/8 in.	18 in.	10 in.
PC122E**	22 Gal.	33 in.	17 in.	9 1/4 in.
PC124**	24 Gal.	25 in.	16 3/4 in.	13 5/8 in.
PC125	25 Gal.	30 5/8 in.	17 5/8 in.	12 1/8 in.
PC126	26 Gal. (100L)	27 in.	19 in.	13 in.
PC129	29 Gal.	24 1/4 in.	24 1/4 in.	12 3/4 in.
PC132A	32 Gal.	34 1/8 in.	17 1/8 in.	14 1/8 in.
PC132B	32 Gal.	25 3/4 in.	25 3/4 in.	13 5/8 in.
PC144	44 Gal.	25 3/4 in.	25 3/4 in.	17 in.

**1 US. Gallon = 3,785L      1 in. = 25,4mm**





**SPORTSMAN-CELL**  
**Sport Fuel Cell**  
**FIA-SCCA-NHRA-SCORE Approved**  
**Note! Not for Nitro & Alcohol use!**



**Sportsman**

Part no	Volume	Length	Width	Height
SM105	5 Gal.	13 1/2 in.	13 1/2 in.	8 1/4 in.
SM108A	8 Gal.	20 1/8 in.	8 5/8 in.	12 1/8 in.
SM108B	8 Gal.	20 1/8 in.	12 1/8 in.	8 5/8 in.
SM110	10 Gal.	25 5/8 in.	10 1/8 in.	10 1/8 in.
SM112	12 Gal.	20 1/8 in.	17 1/8 in.	9 1/8 in.
SM115	15 Gal.	24 5/8 in.	17 1/8 in.	9 1/8 in.
SM117	17 Gal.	20 1/8 in.	17 1/8 in.	12 3/4 in.
SM118A	18 Gal.	28 in.	17 1/8 in.	9 7/8 in.
SM118B	18 Gal.	33 1/2 in.	20 in.	6 1/2 in.
SM118C	18 Gal.	33 1/2 in.	20 in.	6 1/2 in.
SM122A	22 Gal.	34 in.	17 1/2 in.	9 1/2 in.
SM122B	22 Gal.	25 in.	16 3/4 in.	13 5/8 in.
SM122C	22 Gal.	25 3/4 in.	25 3/4 in.	8 1/2 in.
SM124*	24 Gal.	25 in.	16 3/4 in.	13 5/8 in.
SM125	25 Gal.	30 5/8 in.	17 5/8 in.	12 1/8 in.
SM126*	26 Gal. (100L)	27 in.	19 in.	13 in.
SM129	29 Gal.	24 1/4 in.	24 1/4 in.	12 3/4 in.
SM132A	32 Gal.	34 1/8 in.	17 1/8 in.	14 1/8 in.
SM132B	32 Gal.	25 3/4 in.	25 3/4 in.	13 5/8 in.
SM144	44 Gal.	25 3/4 in.	25 3/4 in.	17 in.

**1 US. Gallon = 3,785L      1 in. = 25,4mm**





## ENDURO-CELL

FIA-SCCA-NHRA Approved

**Note!** Designed for Pump Gasoline

(If Nitro or Alkohol is used, Foam baffling must be removed).



### Enduro

Part no	Volume	Length	Width	Height
ED105	5 Gal.	13 1/2 in.	13 1/2 in.	8 1/4 in.
ED108	8 Gal.	20 5/8 in.	15 1/2 in.	7 7/8 in.
ED112	12 Gal.	20 1/2 in.	17 5/8 in.	9 3/8 in.
ED115	15 Gal.	25 3/4 in.	17 5/8 in.	9 3/8 in.
ED122A*	22 Gal.	33 3/4 in.	17 5/8 in.	9 1/4 in.
ED122B	22 Gal.	25 in.	17 in.	13 1/2 in.
ED125	25 Gal.	25 5/8 in.	17 1/2 in.	14 3/8 in.
ED132A-LM*	32 Gal.	25 1/2 in.	17 3/8 in.	18 3/4 in.
ED132A	32 Gal.	25 5/8 in.	17 1/2 in.	18 1/4 in.
ED132B	32 Gal.	33 3/4 in.	17 1/2 in.	14 3/8 in.

1 US. Gallon = 3,785L      1 in. = 25,4mm





## REPLACEMENT BLADDERS FOR PRO CELL, SPORTSMAN, & ENDURO



### Pro Cell Bladders

Part no	Volume	To Fit
RB105	5 Gal.	PC105
RB108A	8 Gal.	PC108A
RB108B	8 Gal.	PC108B
RB109	8 Gal.	PC109
RB110	10 Gal.	PC110
RB112	12 Gal.	PC112
RB115A-M	15 Gal.	PC115A-M
RB115	15 Gal.	PC115
RB117	18 Gal.	PC117
RB118A	18 Gal.	PC118A
RB118B	18 Gal.	PC118B
RB118C	18 Gal.	PC118C
RB122A	22 Gal.	PC122A
RB122B	22 Gal.	PC122B
RB122C	22 Gal.	PC122C
RB122D	22 Gal.	PC122D
RB122E	22 Gal.	PC122E
RB122E-L	22 Gal.	PC122E-L
RB124	24 Gal.	PC124
RB124-L	24 Gal.	PC124-L
RB125	25 Gal.	PC128
RB126	26 Gal.	PC126
RB129	29 Gal.	PC129
RB132A	32 Gal.	PC132A
RB132B	32 Gal.	PC132B
RB144	44 Gal.	PC144

### Sportsman Bladders

Part no	Volume	To Fit
RB205	5 Gal.	SM105
RB208A	8 Gal.	SM108A
RB208B	8 Gal.	SM108B
RB210	10 Gal.	SM110
RB212	12 Gal.	SM112
RB215	15 Gal.	SM115
RB217	18 Gal.	SM117
RB218A	18 Gal.	SM118A
RB218B	18 Gal.	SM118B
RB218C	18 Gal.	SM118C
RB222A	22 Gal.	SM122A
RB222B	22 Gal.	SM122B
RB222C	22 Gal.	SM122C
RB	25 Gal.	SM128
RB226	26 Gal.	SM126
RB229	29 Gal.	SM129
RB232A	32 Gal.	SM132A
RB232B	32 Gal.	SM132B
RB244	44 Gal.	SM144

### Enduro Cell Bladders

Part no	Volume	To Fit
RC105	5 Gal.	ED105
RC108	8 Gal.	ED108
RC112	12 Gal.	ED112
RC115	15 Gal.	ED115
RC122A	22 Gal.	ED122A
RC122B	22 Gal.	ED122B
RC125	25 Gal.	ED128
RC132A-LM	32 Gal.	ED132A-LM
RC132A	32 Gal.	ED132A
RC132B	32 Gal.	ED132B

1 US. Gallon = 3,785L      1 in. = 25,4mm



# *Racing Cells*

## STREET & STRIP

These cells are fully TIG welded .095 Aluminium container with Aluminium flush cap.

**”NOTE!!! NOT FIA APPROVED”**



### Street / Strip

Part no	Volume	Length	Width	Height
SS103	3 Gal.	8 1/4 in.	8 1/4 in.	15 1/4 in.
SS105	5 Gal.	12 1/4 in.	12 1/4 in.	8 3/4 in.
SS110	10 Gal.	20 1/8 in.	12 1/8 in.	8 5/8 in.
SS115	15 Gal.	20 1/4 in.	18 1/4 in.	10 1/4 in.
SS120	20 Gal.	24 1/4 in.	20 1/4 in.	10 1/4 in.

**1 US. Gallon = 3,785L      1 in. = 25,4mm**



**ACCESSORIES  
FOR  
PRO CELL, SPORTSMAN, ULTRA & RACE SAFE**



**Standard 6 X 10 Steel**

**Part no**

**SF6X10A** w/2 1/2" Filler Cap



**Standard 6 X 10 Aluminium**

**Part no**

**SF6X10C** Blank 6 x 10 Plate



**Standard 4 X 6 w/Flush Cap**

**Part no**

**SF4X6A** Standard Ligth Weight



**Multi Location 6 X 10 Steel**

**Part no**

**ML6X10A** Multi Location 6 x10 Plate

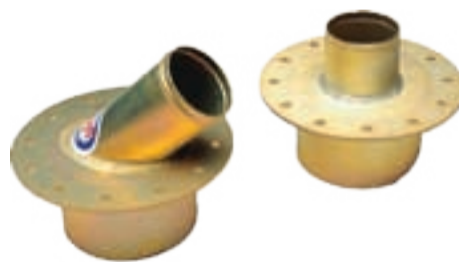

**Remote 2 1/4" & 2 1/2" Fill Valves**

**Part no**

**FV245A** 2 1/4" 45° Roll Over Valve

**FV290A** 2 1/4" 90° Roll Over Valve

**FV245B** 2 1/2" 45° Roll Over Valve

**FV290B** 2 1/2" 90° Roll Over Valve







## REFUELING ACCESSORIES



**Dry Break Valve**

**Part no**

**DBM275** 2 1/4" Dry Brake Valve w/ Handele



**Double Dry Break Valve**

**Part no**

**DDBM225** Male Probe

**DDBF225** Female Receptacle (4,5" center only)



**Dry Break Valve**

**Part no**

**DBF300R** (Female) Redhead\*

**DBM200R** (Male) Redhead\*



**Dry Break Valve**

**Part no**

**DBM225A** 2 1/4" (Male)

**DBF225A** 2 1/4 (Female)

\*Redhead is the registered trademark of Induction Systems



**Dry Break Valve**

**Part no**

**DBF225-B** (Female) 4" B,C

**DBF225-C** (Female) 4 3/4" B,C



**Dry Break Rebuild Kit  
(for Redhead Dry Breaks only)**

**Part no**

**PP20F** Female

**PP20M** Male



## FUEL SAFE ACCESSORIES



### Check Valves

Part no	
ITV08	1/1" Vent Check Valve for remote fill. Mounts in fill plate. Offers positive shut-off.
ITV08S	1/2" Vent Check Valve w/spring for standard fill. Mounts in fill plate. Offers positive shut-off.
ITV06	3/8" Vent Check Valve for remote fill. Mounts in fill plate. Offers positive shut-off.
ITV06S	3/8" Vent Check Valve w/spring for standard fill. Mounts in fill plate.
ILV06	3/8" In Line Vent Check Valve Offers positive shut-off.
ILV08	1/2" In Line Vent Check Valve Offers positive shut-off.



### Gaskets

Part no	
OG024	24 Bolt Oval 6 x10
OG012	12 Bolt Oval 4 x 6
CG012A	12 Bolt Circle 4 3/4" B.C.
CG012B	12 Bolt Circle 5 3/8" B.C.
CG010	10 Bolt Circle 3 1/8" B.C.
CG009	9 Bolt Circle 4" B.C.
CG006A	6 Bolt Circle 2 15/16" B.C.
CG006B	6 Bolt Circle 2 3/8" B.C.
CG006C	6 Bolt Circle 2" B.C.
CG005	5 Bolt Circle (sending Unit)
CG004	4 Bolt Circle 1 5/8" B.C.



### Discriminator Valves

The ultimate in fuel venting.  
This valve offers fuel shut-off when refueling  
and eliminates the need for a catch can.  
Also offers positive shut-off in case of a rollover

Part no	
DV100	1"
DV175	1 3/4"



### Roll Over Valve

Part no	
RV38	3/8" Inline Roll Over Vent Valve



### 1" in Tank Check Valve

Mounts in bladder or cell.  
This valve offers positive Shut-Off

Part no	
ITV100	1" Check Valve
ITV175	1 3/4" Check Valve



## FUEL SAFE ACCESSORIES



### Fuel Pick-up Kit

Kit contains: 2' of hose; (1) hose barb;  
and (1) bulkhead fitting (not shown)

Part no	
FP180	3/8" -06 AN
FP181	1/2" -08 AN
FP182	5/8" -10 AN
FP183	3/8" -12 AN



### In-Tank Fuel Pump Assembly

Part no	
FP150	GM In-Tank style fuel pump
FP115	Vortec ASA 5700
1ELE15	In-Tank Low pressure pump
FS15	Filter



### Fuel Pick-Up Screen

Part no	
FS38	3/8 in, Horizontal Screen
FS12	1/2 in. Horizontal Screen
1FLU29	Vertical Screen

(Specify -06 or -08 AN hose barb)



### In-Tank Fuel Screen

Part no	
FS120	#12 - 90°





## FUEL SAFE ACCESSORIES



### Dip Stick

Economy Fuel Gauge, check your fuel level by a twist of a nut.

Part no	
DS08	Specify length needed.



### Fuel Displacement Block

Part no	
DB200	2 Gal. Block 5" x 8" x 12"
DB100	1 Gal. Block 6" x 6" x 6"
DB050	1/2 Gal. Block 8 3/4" x 3 1/2" x 3 1/2"
DB025	1/8 Gal. Block 2 7/8" x 2 7/8" x 3 3/8"



### Electronic Sending Unit

New electronic fuel level sending units are specially designed for fuel cells and bladders. No moving parts makes this units very durable. Sending unit can be shortened to fit your cell and re-adjusted for accuracy.

Part no	
SU006	6" - can shortened to 3"
SU012	12" - can shortened to 6"
SU012L	12" - can shortened to 6"
SU024	24" - can shortened to 12"
SU024L	24" - can shortened to 12"
GA200	Gas Gauge
	L = Lowlight Warning



### 2 1/4" & 3" Rubber Elbows

45° and 90° tough rubber elbows for use with remote fill plates.

Part no	
RE90	3" - 90°
RE45	3" - 45°
RE90	2 1/4" - 90°
RE45	2 1/4" - 45°



# Hose Finishers

Dress up any installation with none thread application



Part no Red	Part no Blue	Part no Chrome	Part no Black	ø ID.mm.	Max Hose OD.mm.
9001-04	9002-04	9003-04	9004-04	6,4	12,7
9001-06	9002-06	9003-06	9004-06	8,8	16,0
9001-08	9002-08	9003-08	9004-08	11,0	17,5
9001-10	9002-10	9003-10	9004-10	15,5	21,0
9001-12	9002-12	9003-12	9004-12	20,2	24,9
9001-14	9002-14	9003-14		19,0	28,6
9001-16	9002-16	9003-16		23,1	30,2
9001-18	9002-18	9003-18		28,0	34,9
9001-20	9002-20	9003-20		32,0	39,7
9001-24	9002-24	9003-24		38,3	42,9
9001-28	9002-28	9003-28		43,7	49,2
9001-32	9002-32	9003-32		51,0	55,6
9001-34	9002-34	9003-34		53,1	58,5
9001-36	9002-36	9003-36		57,1	60,3



# Hose Separators

Aluminium Hose and Tubing Separators  
Allows Professional plumbing installation



Part no Red	Part no Blue	Part no Chrome	Max Hose OD.mm.
167003RD	167003BU	167003CH	4,75
167004RD	167004BU	167004CH	6,4
167005RD	167005BU	167005CH	8,0
167006RD	167006BU	167006CH	9,5
167007RD	167007BU	167007CH	11,0
167008RD	167008BU	167008CH	12,5
167009RD	167009BU	167009CH	14,3
167010RD	167010BU	167010CH	16,0
167011RD	167011BU	167011CH	17,5
167012RD	167012BU	167012CH	19,0
167013RD	167013BU	167013CH	20,6
167014RD	167014BU	167014CH	22,2
167015RD	167015BU	167015CH	23,8
167016RD	167016BU	167016CH	25,4
167017RD	167017BU	167017CH	27,0
167019RD	167019BU	167019CH	31,0
167020RD	167020BU	167020CH	32,5
167022RD	167022BU	167022CH	51,6



Part no Red	Part no Blue	Part no Chrome	Qty. per Pkg	Max Hose OD.mm.
170003RD	170003BU	170003CH	6	4,75
170004RD	170004BU	170004CH	6	6,4
170005RD	170005BU	170005CH	6	8,0
170006RD	170006BU	170006CH	4	9,5
170007RD	170007BU	170007CH	4	11,0
170008RD	170008BU	170008CH	3	12,5
170009RD	170009BU	170009CH	3	14,3



# *Power Steering Pump*

## Electrical Power Steering Pump.

Get "The Clean Look" on your engine  
Hide The Pump Under The Car

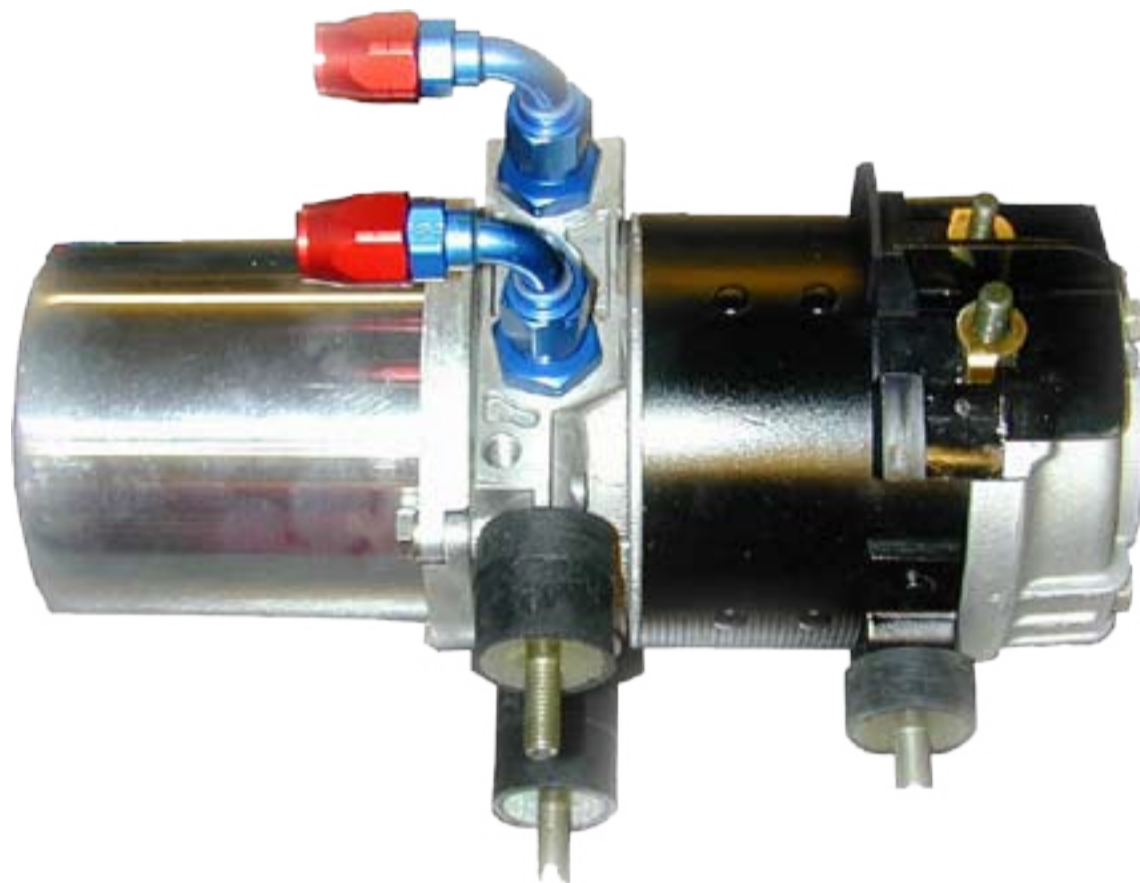

**Pressure:** max 80bar (1140psi)  
**Voltage:** 12V  
**Weight:** 5Kg  
**Length:** 260mm  
**Width:** 130mm  
**Height:** 120mm

Part no

17-525 Power steering Pump

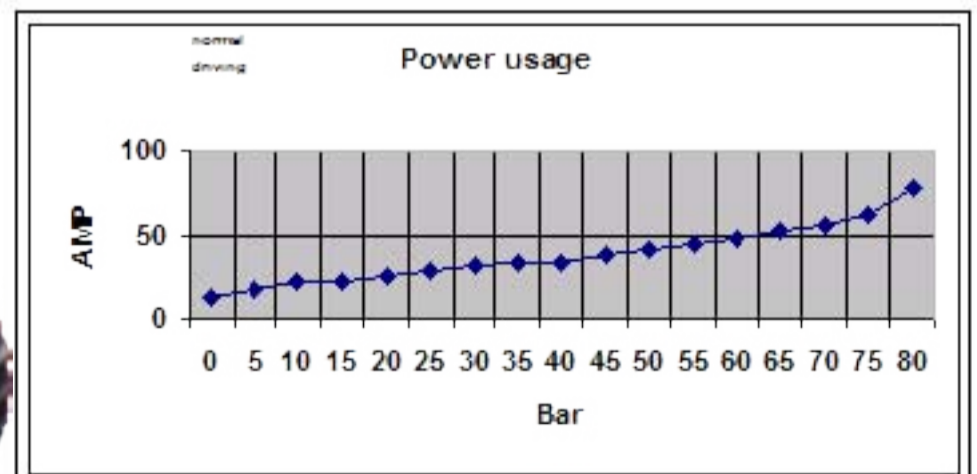



## Skiving Machine.

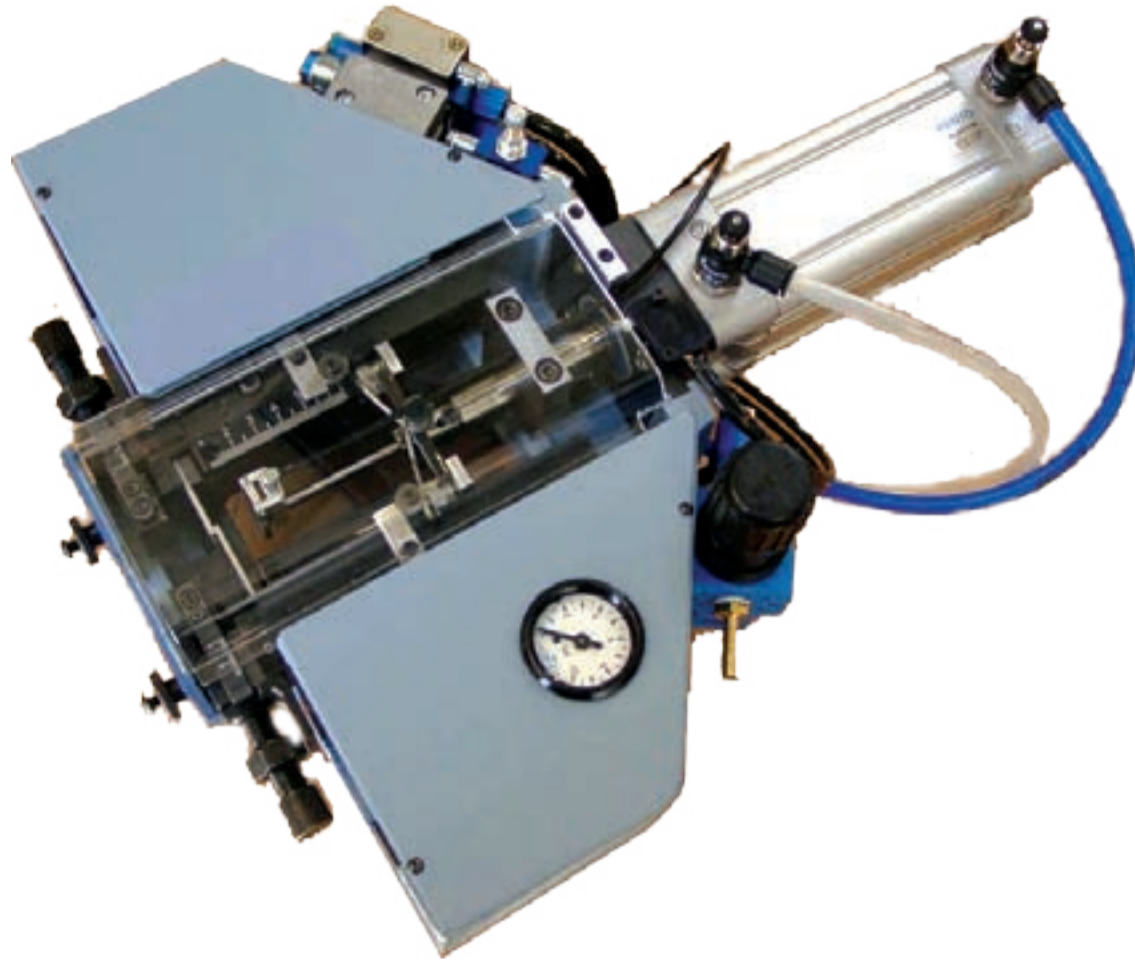

Part no	
9990000	Skiving Machine

## Ferrule Mounting Tool. Ferrule Mounting On Hose



Part no	
999-61-00	Ferrule Mouting Tool

## Crimper.



Part no	
990	Crimper





## Quick-Connect Fluid Fittings



Quick-Connect Fittings for Oil and Fuel  
**Coming Products Spring 2005**







## Quick-Connect Fluid Fittings



Quick-Connect Fittings for Oil and Fuel  
**Coming Products Spring 2005**

