

Brake System



Tilton Master Cylinder Kit

Part no	Dim.
74-625U	0,625" = 15,87mm
74-700U	0,700" = 17,78mm
74-750U	0,750" = 19,05mm
74-812U	0,812" = 20,62mm
74-875U	0,875" = 22,22mm
74-1000U	1,0" = 25,4mm
74-1125U	1,125" = 28,57mm

Tilton Master Cylinder Kit

Part no	Dim.
75-625U	0,625" = 15,87mm
75-700U	0,700" = 17,78mm
75-750U	0,750" = 19,05mm
75-812U	0,812" = 20,62mm
75-875U	0,875" = 22,22mm
75-1000U	1,0" = 25,4mm
75-1125U	1,125" = 28,57mm



Brake System



Brake Fluid Container
 ø 55mm Height 50mm
 Thread AN -04 = 7/16-20

Part no
70005



Brake Fluid Container
 ø 55mm Height 70mm
 Thread AN -04 = 7/16-20

Part no
70007



Girling Master Cylinder

Part no	Dim.
70-162	0,625" = 15,87mm
70-170	0,700" = 17,78mm
70-175	0,750" = 19,05mm



Residual Pressure Valve
 Blue = 2 lbs = 0,9bar

Part no	Thread
90-1874	1/8 NPT Female

Brake System



Remote controll for Balance Bar

Part no
72-501



Balance Bar Assembly
with 3/8-24 Therad

Part no
72-250



Proportioning Valve
with Lever Tilton

Part no
90-100



Proportioning Valve
Rotory Style Tilton

Part no
90-200



Proportioning Valve
Rotory Style Wilwood

Part no
901-220



Fuel & Oil Hose

Stainless Steel Braided Rubber



In recent years fuel manufactures has add different unpublished additives in their fuel, as a result of this it is impossible to say how this will affect the rubber in our or others rubber hose.

"It is impossible to guarantee use without problem with the rubber hose"

If in doubt use Teflon Hose.

Stainless Steel Braided
Working.temp. -46°C to +150°C

Part no	Bore Size mm	Braid O/D mm	Bend Radius mm	Working Pressure bar	Weight Kg/m
300-04	5,56	11,11	50	102	0,169
300-05	6,35	12,70	50	102	0,190
300-06	8,75	13,89	64	102	0,200
300-07	9,52	15,09	76	102	0,240
300-08	11,12	16,35	89	102	0,271
300-10	14,32	20,30	102	85	0,348
300-11	15,28	21,55	110	70	0,360
300-12	17,33	24,00	115	70	0,420
300-14	19,05	26,20	125	60	0,495
300-16	22,20	29,20	140	50	0,565
300-18	25,40	33,40	175	40	0,650
300-20	28,70	35,80	205	35	0,730
300-24	34,05	43,20	225	20	1,190
300-28	38,10	47,00	255	15	1,340
300-32	44,45	54,00	305	14	1,458

*Note. Pressure limit factor is for the hose
 (With mounted fittings is maximum pressure 17bar)*



Straight Female Swivel

Part no	Hose Size	JIC/UNF Thread
8001-06	-06	9/16 x 18
8001-08	-08	3/4 x 16
8001-10	-10	7/8 x 14
8001-12	-12	1 1/16 x 12
8001-16	-16	1 5/16 x 12

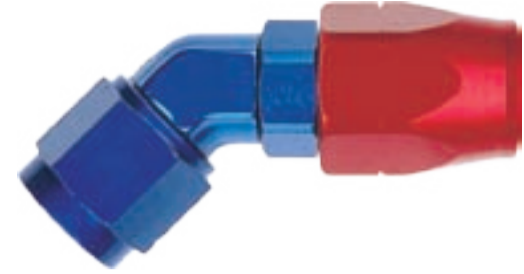

45° Female Forged Elbow

Part no	Hose Size	JIC/UNF Thread
8045-06	-06	9/16 x 18
8045-08	-08	3/4 x 16
8045-10	-10	7/8 x 14
8045-12	-12	1 1/16 x 12
8045-16	-16	1 5/16 x 12

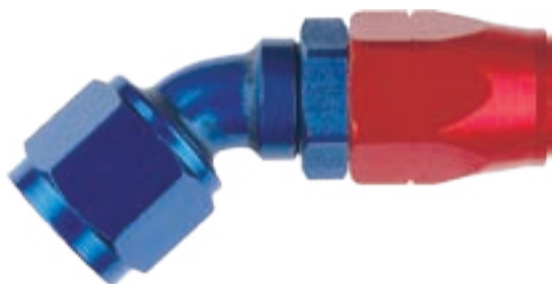

45° Female Swept Tube

Part no	Hose Size	JIC/UNF Thread
8046-06	-06	9/16 x 18
8046-08	-08	3/4 x 16
8046-10	-10	7/8 x 14
8046-12	-12	1 1/16 x 12
8046-16	-16	1 5/16 x 12

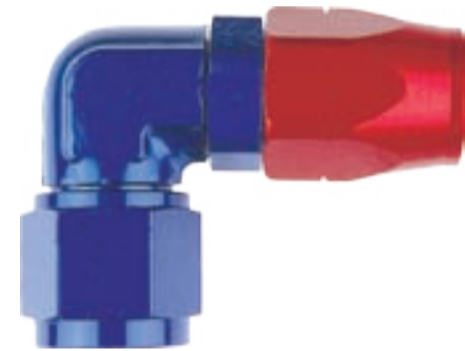

90° Female Forged Elbow

Part no	Hose Size	JIC/UNF Thread
8090-06	-06	9/16 x 18
8090-08	-08	3/4 x 16
8090-10	-10	7/8 x 14
8090-12	-12	1 1/16 x 12
8090-16	-16	1 5/16 x 12



90° Female Swept Tube

Part no	Hose Size	JIC/UNF Thread
8091-06	-06	9/16 x 18
8091-08	-08	3/4 x 16
8091-10	-10	7/8 x 14
8091-12	-12	1 1/16 x 12
8091-16	-16	1 5/16 x 12



120° Female Swept Tube

Part no	Hose Size	JIC/UNF Thread
8120-06	-06	9/16 x 18
8120-08	-08	3/4 x 16
8120-10	-10	7/8 x 14
8120-12	-12	1 1/16 x 12
8120-16	-16	1 5/16 x 12

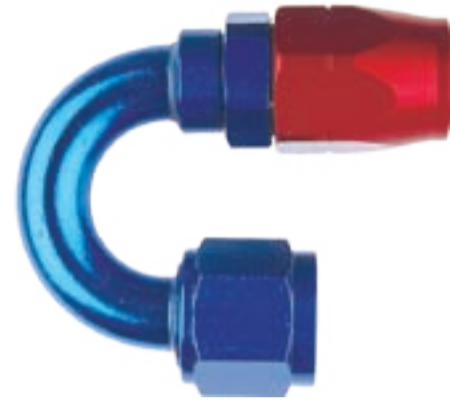

150° Female Swept Tube

Part no	Hose Size	JIC/UNF Thread
8150-06	-06	9/16 x 18
8150-08	-08	3/4 x 16
8150-10	-10	7/8 x 14
8150-12	-12	1 1/16 x 12
8150-16	-16	1 5/16 x 12

180° Female Swept Tube

Part no	Hose Size	JIC/UNF Thread
8180-06	-06	9/16 x 18
8180-08	-08	3/4 x 16
8180-10	-10	7/8 x 14
8180-12	-12	1 1/16 x 12
8180-16	-16	1 5/16 x 12



Stright Banjo

Part no	Hose Size	Bolt Thread
8076-91	-06	M12 x 1,25
8076-92	-06	M12 x 1,5
8076-94	-06	9/16-24
8076-95	-06	1/2-20



Stright Double Banjo

Part no	Hose Size	Bolt Thread
8079-91	-06	M12 x 1,25
8079-92	-06	M12 x 1,5
8079-94	-06	9/16-24
8079-95	-06	1/2-20



Stright Male

Part no	Hose Size	NPT Thread
3201-04	-04	1/8
3201-44	-04	1/4
3201-62	-06	1/8
3201-06	-06	1/4
3201-66	-06	3/8
3201-07	-08	1/4
3201-08	-08	3/8
3201-88	-08	1/2
3201-11	-10	3/8
3201-10	-10	1/2
3201-12	-12	3/4
3201-13	-12	1/2



Tube-Mate Auto-Fit

Part no	Hose Size	Tube Size
3601-04	-04	1/4
3601-65	-06	5/16
3601-06	-06	3/8
3601-08	-08	1/2
3601-10	-10	5/8
3601-12	-12	3/4



Fuel & Oil Hose

Synthetic Rubber Tube

Textile braid reinforcement and synthetic rubber cover

**"Push on" Hose is a high quality hose for fuel and lubrication oil, air and water.
Constructed for use with the "Push On" fittings without clamp**



Synthetic Rubber Cover

One layer Textile braid reinforcement

Temp range -40°C to +150°C

Part no	Bore Size mm	Braid O/D mm	Bend Radius mm	Working Pressure bar	Weight Kg/m
2556-04	6,35	12,70	76	17	0,119
2556-06	9,65	15,75	76	17	0,163
2556-08	12,70	19,05	127	17	0,238
2556-10	15,75	23,10	152	17	0,297
2556-12	19,05	26,15	178	17	0,342

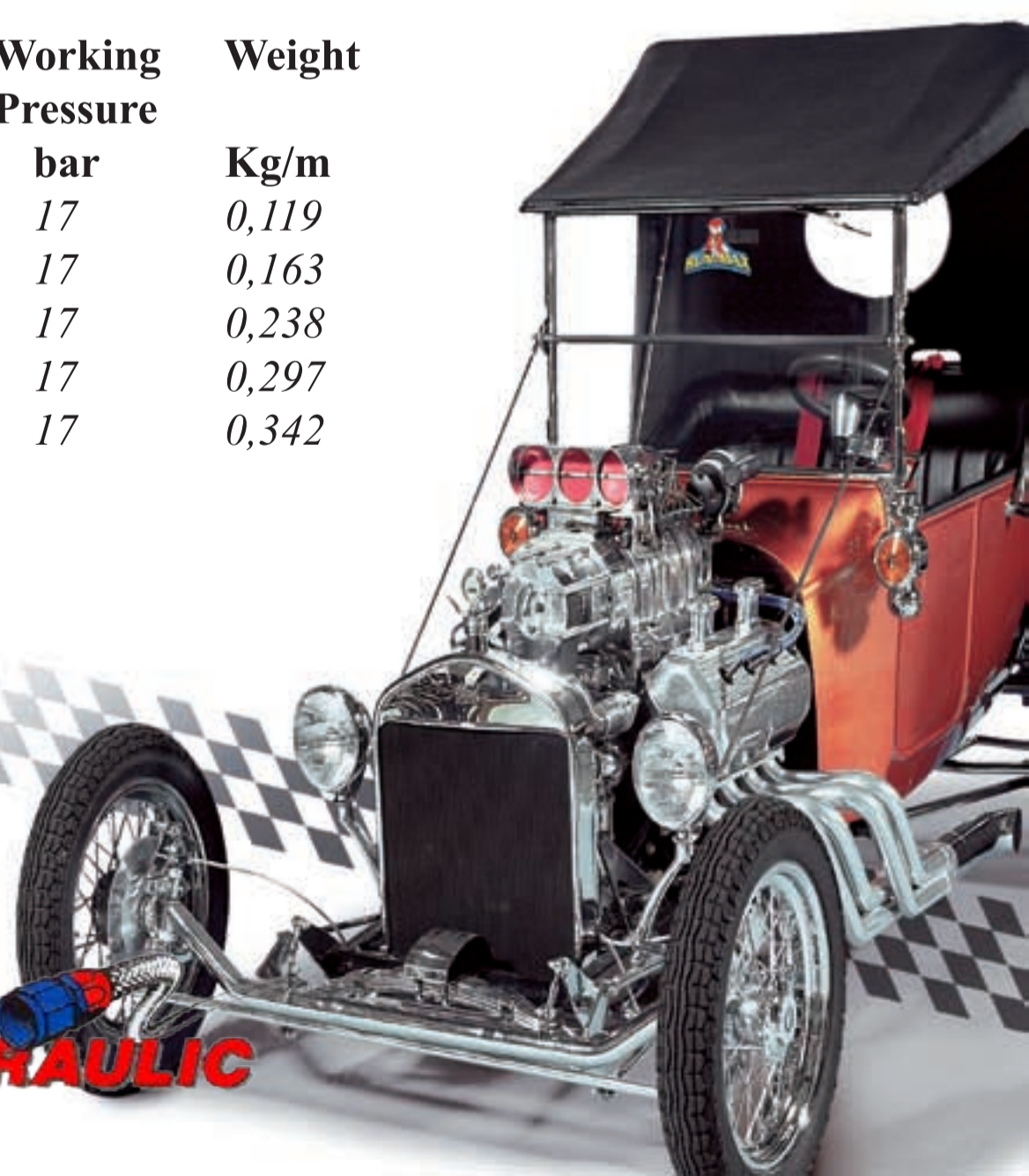



Straight Female Swivel

Part no	Hose Size	JIC/UNF Thread
7001-45	-04	7/16 x 14
7001-67	-06	9/16 x 18
7001-09	-08	3/4 x 16
7001-11	-10	7/8 x 14
7001-13	-12	1 1/16 x 12

45° Female Swept Tube

Part no	Hose Size	JIC/UNF Thread
7046-45	-04	7/16 x 14
7046-67	-06	9/16 x 18
7046-09	-08	3/4 x 16
7046-11	-10	7/8 x 14
7046-13	-12	1 1/16 x 12

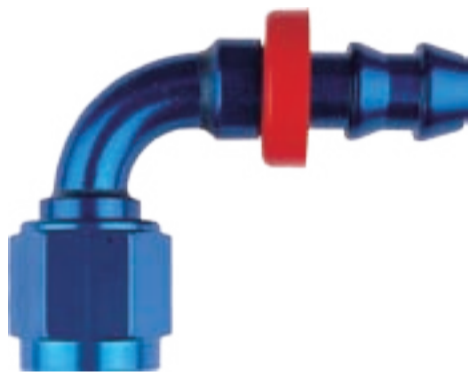

90° Female Swept Tube

Part no	Hose Size	JIC/UNF Thread
7091-45	-04	7/16 x 14
7091-67	-06	9/16 x 18
7091-09	-08	3/4 x 16
7091-11	-10	7/8 x 14
7091-13	-12	1 1/16 x 12

120° Female Swept Tube

Part no	Hose Size	JIC/UNF Thread
7120-45	-04	7/16 x 14
7120-67	-06	9/16 x 18
7120-09	-08	3/4 x 16
7120-11	-10	7/8 x 14
7120-13	-12	1 1/16 x 12

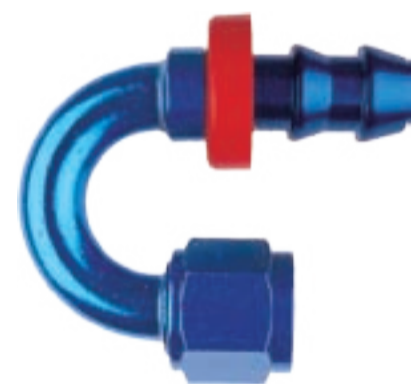

150° Female Swept Tube

Part no	Hose Size	JIC/UNF Thread
7150-45	-04	7/16 x 14
7150-67	-06	9/16 x 18
7150-09	-08	3/4 x 16
7150-11	-10	7/8 x 14
7150-13	-12	1 1/16 x 12

180° Female Swept Tube

Part no	Hose Size	JIC/UNF Thread
7180-45	-04	7/16 x 14
7180-67	-06	9/16 x 18
7180-09	-08	3/4 x 16
7180-11	-10	7/8 x 14
7180-13	-12	1 1/16 x 12



Convolutd light weight ptfe steel/nomex braided

Hose "top of the line" the best you can buy today

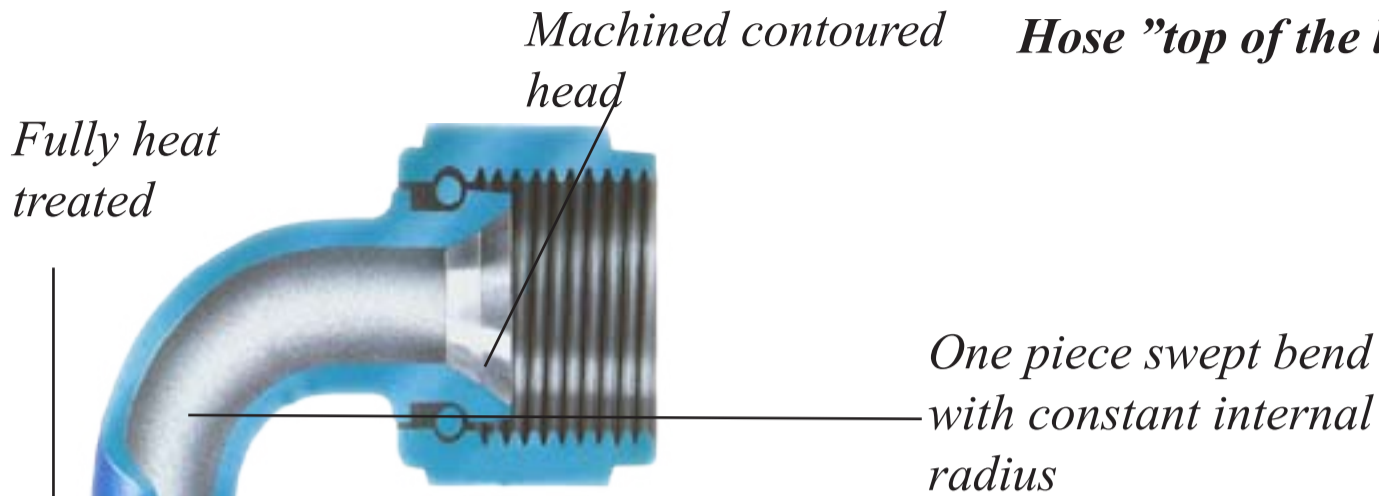

Stainless Steel Braid
Temp Range -54°C to +204°C

Part no	Nom Hose Size	Bore Size mm	Braid O/D mm	Bend Radius mm	Working Pressure bar	Weight Kg/m
AR-06-S	3/8	9.14	13.71	25.4	34.50	0.16
AR-08-S	1/2	10.92	15.74	38.1	34.50	0.19
AR-10-S	5/8	13.71	19.05	50.8	34.50	0.27
AR-12-S	3/4	16.76	22.35	63.5	34,50	0.32
AR-16-S	1	22.1	27.43	88.9	34,50	0.39

Nomex Braid
Temp Range -54°C to +150°C

Part no	Nom Hose Size	Bore Size mm	Braid O/D mm	Bend Radius mm	Working Pressure bar	Weight Kg/m
AR-06-N	3/8	9.14	13.71	25.4	17.25	0.09
AR-08-N	1/2	10.92	15.74	38.1	17.25	0.12
AR-10-N	5/8	13.71	19.05	50.8	17.25	0.19
AR-12-N	3/4	16.76	22.35	63.5	17.25	0.20
AR-16-N	1	22.1	27.43	88.9	17.25	0.25

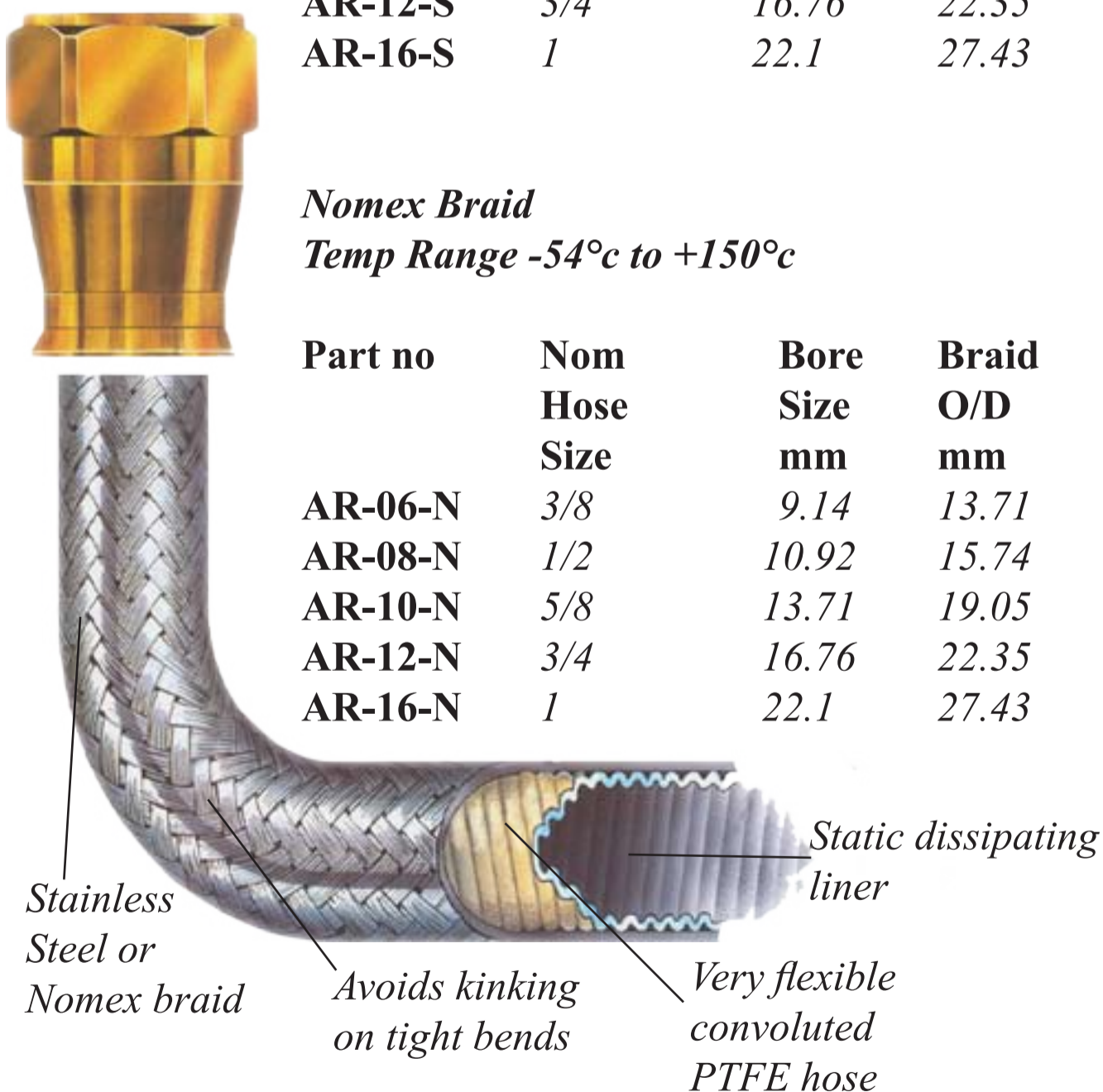

ProGold Assembly

Assembly Procedure for ProGold "AR" Reusable Fittings

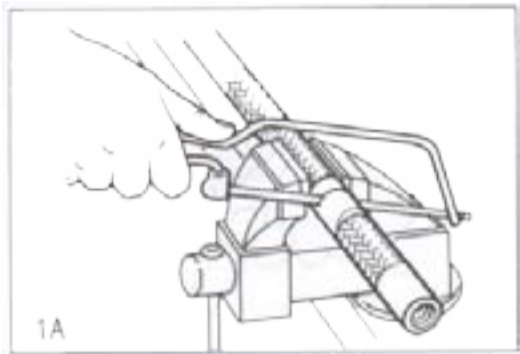

Metallic Braid: To minimise braid flare wrap the area of the hose to be cut with masking tape.
Cut the hose with a suitable fine toothed hack saw blade. Remove the tape before next step.



Non-metallic Braid: Wrap PTFE (teflon) thread tape on area to be cut. DO NOT use adhesive tape of any type. Cut the hose with a suitable sharp knife then carefully remove the tape.

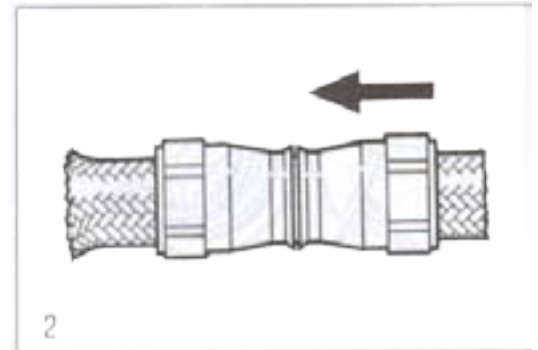

Braid tends to flare more at one end than the other. Assemble both sockets to back from the less flared end.

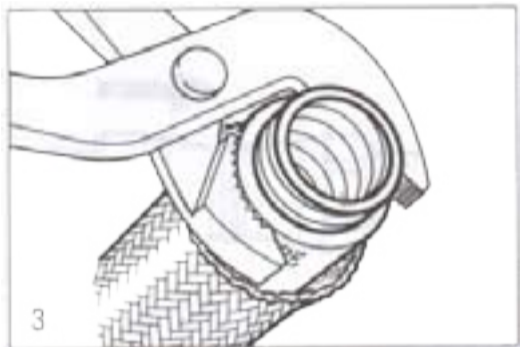

Screw the olive onto the hose until the hose protrudes through the olive. Don't cross thread or force the olive. Make sure the braid goes over the olive.

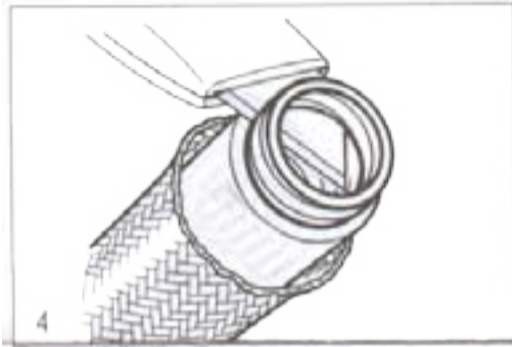

Trim the hose back to be flush or a maximum of 1mm proud of the olive.

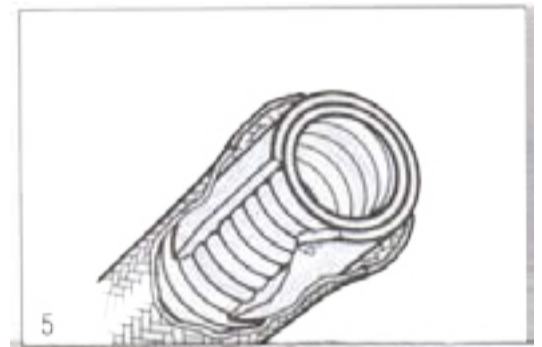

Ensure the hose is cut cleanly and square.

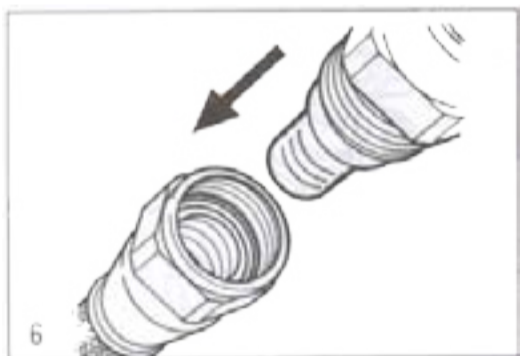

Pull the sockets up over the olives. Lubricate the fitting thread with a light oil. Insert the tail into the hose. Engage the fitting and socket threads. Screw together as far as possible by hand.

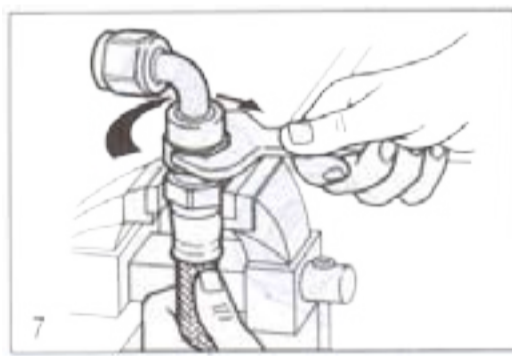

Lightly grip the socket in a set of vice jaws and fully tighten the fitting. (see the picture).

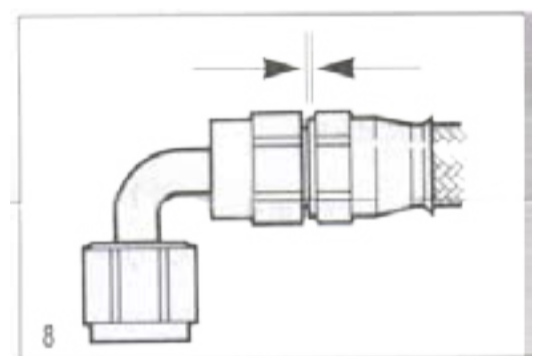

Metallic Braid: Socket should be no more than 1mm away from the fitting face.
Non-Metallic Braid: Socket should be touching the fitting face.

Clean the assembly fittings and pressure test the assembly to twice the system working pressure.

NEVER Loosen fittings once assembled to achieve the desired orientation.
ALWAYS Use a new olive when reusing an end fitting.
IF IN DOUBT Consult Icore or Your nearest stockist.



Straight Female Swivel

Part no	Hose Size	JIC/UNF Thread
AR-06-F3	-06	9/16 x 18
AR-08-F3	-08	3/4 x 16
AR-10-F3	-10	7/8 x 14
AR-12-F3	-12	1 1/16 x 12
AR-16-F3	-16	1 5/16 x 12



45° Female Swept Tube

Part no	Hose Size	JIC/UNF Thread
AR-06-G3	-06	9/16 x 18
AR-08-G3	-08	3/4 x 16
AR-10-G3	-10	7/8 x 14
AR-12-G3	-12	1 1/16 x 12
AR-16-G3	-16	1 5/16 x 12



90° Female Swept Tube

Part no	Hose Size	JIC/UNF Thread
AR-06-H3	-06	9/16 x 18
AR-08-H3	-08	3/4 x 16
AR-10-H3	-10	7/8 x 14
AR-12-H3	-12	1 1/16 x 12
AR-16-H3	-16	1 5/16 x 12



120° Female Swept Tube

Part no	Hose Size	JIC/UNF Thread
AR-06-P3	-06	9/16 x 18
AR-08-P3	-08	3/4 x 16
AR-10-P3	-10	7/8 x 14
AR-12-P3	-12	1 1/16 x 12
AR-16-P3	-16	1 5/16 x 12



150° Female Swept Tube

Part no	Hose Size	JIC/UNF Thread
AR-06-R3	-06	9/16 x 18
AR-08-R3	-08	3/4 x 16
AR-10-R3	-10	7/8 x 14
AR-12-R3	-12	1 1/16 x 12
AR-16-R3	-16	1 5/16 x 12



180° Female Swept Tube

Part no	Hose Size	JIC/UNF Thread
AR-06-S3	-06	9/16 x 18
AR-08-S3	-08	3/4 x 16
AR-10-S3	-10	7/8 x 14
AR-12-S3	-12	1 1/16 x 12
AR-16-S3	-16	1 5/16 x 12

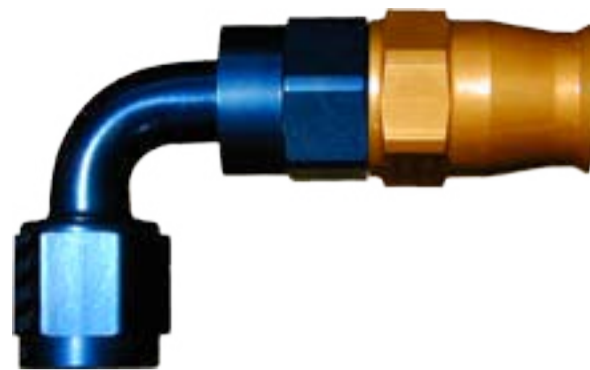

45° Female Swept Double swivel Tube

Part no	Hose Size	JIC/UNF Thread
AR-06-G3-DS	-06	9/16 x 18
AR-08-G3-DS	-08	3/4 x 16
AR-10-G3-DS	-10	7/8 x 14
AR-12-G3-DS	-12	1 1/16 x 12
AR-16-G3-DS	-16	1 5/16 x 12

90° Female Swept Double swivel Tube

Part no	Hose Size	JIC/UNF Thread
AR-06-H3-DS	-06	9/16 x 18
AR-08-H3-DS	-08	3/4 x 16
AR-10-H3-DS	-10	7/8 x 14
AR-12-H3-DS	-12	1 1/16 x 12
AR-16-H3-DS	-16	1 5/16 x 12



120° Female Swept Double swivel Tube

Part no	Hose Size	JIC/UNF Thread
AR-06-P3-DS	-06	9/16 x 18
AR-08-P3-DS	-08	3/4 x 16
AR-10-P3-DS	-10	7/8 x 14
AR-12-P3-DS	-12	1 1/16 x 12
AR-16-P3-DS	-16	1 5/16 x 12

150° Female Swept Double swivel Tube

Part no	Hose Size	JIC/UNF Thread
AR-06-R3-DS	-06	9/16 x 18
AR-08-R3-DS	-08	3/4 x 16
AR-10-R3-DS	-10	7/8 x 14
AR-12-R3-DS	-12	1 1/16 x 12
AR-16-R3-DS	-16	1 5/16 x 12



180° Female Swept Double swivel Tube

Part no	Hose Size	JIC/UNF Thread
AR-06-S3-DS	-06	9/16 x 18
AR-08-S3-DS	-08	3/4 x 16
AR-10-S3-DS	-10	7/8 x 14
AR-12-S3-DS	-12	1 1/16 x 12
AR-16-S3-DS	-16	1 5/16 x 12



Straight Female Metric

Part no	Hose Size	Thread
AR-06-ST-M12	-06	M12 X 1,5
AR-06-ST-M14	-06	M14 X 1,5
AR-06-ST-M16	-06	M16 X 1,5
AR-08-ST-M18	-08	M18 X 1,5
AR-10-ST-M22	-10	M22 X 1,5



45° Swept Female Swivel Metric

Part no	Hose Size	Thread
AR-06-45-M12	-06	M12 x 1,5
AR-06-45-M14	-06	M14 x 1,5
AR-06-45-M16	-06	M16 x 1,5
AR-06-45-M18	-08	M18 x 1,5
AR-06-45-M22	-10	M22 x 1,5



Socket

Part no
AR-S-06
AR-S-08
AR-S-10
AR-S-12
AR-S-16



90° Swept Female Swivel Metric

Part no	Hose Size	Thread
AR-06-90-M12	-06	M12 x 1,5
AR-06-90-M14	-06	M14 x 1,5
AR-06-90-M16	-06	M16 x 1,5
AR-06-90-M18	-08	M18 x 1,5
AR-06-90-M22	-10	M22 x 1,5

NOTE:
A new Olive **MUST** always be fitted when reusing an end fitting.



Olive

Part no
AR-O-06
AR-O-08
AR-O-10
AR-O-12
AR-O-16



Banjo with Banjo Bolt

Part no	Hose Size	Bolt Thread
AR-06-BJ-01	-06	9/16 x 24
AR-06-BJ-02	-06	M12 x 1,25
AR-06-BJ-03	-06	M12 x 1,5
AR-06-BJ-04	-06	M12 x 1,5



Banjo with Banjo Bolt

Part no	Hose Size	Bolt Thread
AR-06-DBJ-01	-06	9/16 x 24
AR-06-DBJ-02	-06	M12 x 1,25
AR-06-DBJ-03	-06	M12 x 1,5
AR-06-DBJ-04	-06	M12 x 1,5

Aluminium adapters

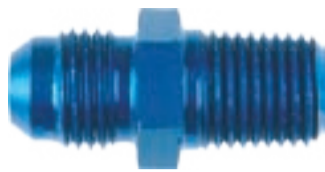

Straight JIC (AN) x NPT

Part no	AN-Dim	Thread
9816-03	-03	1/8
9816-04	-04	1/8
9816-44	-04	1/4
9816-62	-06	1/8
9816-06	-06	1/4
9816-66	-06	3/8
9816-68	-06	1/2
9816-07	-08	1/4
9816-08	-08	3/8
9816-88	-08	1/2
9816-11	-10	3/8
9816-10	-10	1/2
9816-09	-10	3/4
9816-12	-12	3/4
9816-13	-12	1/2
9816-15	-16	3/4
9816-16	-16	1



45° JIC (AN) x NPT

Part no	AN-Dim	Thread
9823-03	-03	1/8
9823-04	-04	1/8
9823-44	-04	1/4
9823-62	-06	1/8
9823-06	-06	1/4
9823-66	-06	3/8
9823-68	-06	1/2
9823-07	-08	1/4
9823-08	-08	3/8
9823-88	-08	1/2
9823-11	-10	3/8
9823-10	-10	1/2
9823-09	-10	3/4
9823-12	-12	3/4
9823-13	-12	1/2
9823-16	-16	1



90° JIC (AN) x NPT

Part no	AN-Dim	Thread
9822-03	-03	1/8
9822-04	-04	1/8
9822-44	-04	1/4
9822-62	-06	1/8
9822-06	-06	1/4
9822-66	-06	3/8
9822-68	-06	1/2
9822-07	-08	1/4
9822-08	-08	3/8
9822-88	-08	1/2
9822-11	-10	3/8
9822-10	-10	1/2
9822-09	-10	3/4
9822-12	-12	3/4
9822-13	-12	1/2
9822-15	-16	3/4
9822-16	-16	1



Straight Swivel on JIC (AN) x NPT

Part no	AN-Dim	Thread
916-03D	-03	1/8
916-04D	-04	1/8
916-44D	-04	1/4
916-62D	-06	1/8
916-06D	-06	1/4
916-66D	-06	3/8
916-07D	-08	1/4
916-08D	-08	3/8
916-88D	-08	1/2
916-11D	-10	3/8
916-10D	-10	1/2
916-12D	-12	3/4
916-13D	-12	1/2

Aluminium adapters



JIC (AN) x NPT On Side

Part no	AN-Dim	Thread
9825-03	-03	1/8
9825-04	-04	1/8
9825-06	-06	1/4
9825-08	-08	3/8
9825-10	-10	1/2
9825-12	-12	3/4



T JIC (AN) x NPT On Run

Part no	AN-Dim	Thread
9826-03	-03	1/8
9826-04	-04	1/8
9826-06	-06	1/4
9826-08	-08	3/8
9826-10	-10	1/2
9826-12	-12	3/4



90° JIC (AN)

Part no	AN-Dim
9821-03	-03
9821-04	-04
9821-06	-06
9821-08	-08
9821-10	-10
9821-12	-12
9821-16	-16



T JIC (AN)

Part no	AN-Dim
9824-03	-03
9824-04	-04
9824-06	-06
9824-08	-08
9824-10	-10
9824-12	-12
9824-16	-16



JIC (AN) Union Reducer

Part no	AN-Dim	AN-Dim
9919-02	-03	-04
9919-03	-05	-04
9919-05	-06	-03
9919-06	-06	-04
9919-07	-06	-05
9919-12	-08	-06
9919-14	-10	-06
9919-15	-10	-08
9919-18	-12	-06
9919-19	-12	-08
9919-20	-12	-10
9919-22	-16	-10
9919-23	-16	-12



JIC (AN) Union Male

Part no	AN-Dim
9815-03	-03
9815-04	-04
9815-06	-06
9815-08	-08
9815-10	-10
9815-12	-12
9815-16	-16

Aluminium adapters



45° JIC (AN) Bulkhead

Part no	AN-Dim
9837-03	-03
9837-04	-04
9837-06	-06
9837-08	-08
9837-10	-10
9837-12	-12



90° JIC (AN) Bulkhead

Part no	AN-Dim
9833-03	-03
9833-04	-04
9833-06	-06
9833-08	-08
9833-10	-10
9833-12	-12
9833-16	-16



T JIC (AN) Bulkhead On Run

Part no	AN-Dim
9804-03	-03
9804-04	-04
9804-06	-06
9804-08	-08



T JIC (AN) Bulkhead On Side

Part no	AN-Dim
9834-03	-03
9834-04	-04
9834-06	-06
9834-08	-08
9834-10	-10
9834-12	-12



JIC (AN) Bulkhead

Part no	AN-Dim
9832-03	-03
9832-04	-04
9832-06	-06
9832-08	-08
9832-10	-10
9832-12	-12
9832-16	-16



Lock Nut

Part no	AN-Dim
9924-03	-03
9924-04	-04
9924-06	-06
9924-08	-08
9924-10	-10
9924-12	-12
9924-16	-16

Aluminium adapters



45° Female AN swivel to male AN

Part no	AN-Dim
9241-03	-03
9241-04	-04
9241-06	-06
9241-08	-08
9241-10	-10
9241-12	-12



90° Female AN swivel to male AN

Part no	AN-Dim
9211-03	-03
9211-04	-04
9211-06	-06
9211-08	-08
9211-10	-10
9211-12	-12



45° Female AN to female AN

Part no	AN-Dim
9391-03	-03
9391-04	-04
9391-06	-06
9391-08	-08
9391-10	-10
9391-12	-12



90° Female AN to female AN

Part no	AN-Dim
9341-03	-03
9341-04	-04
9341-06	-06
9341-08	-08
9341-10	-10
9341-12	-12



AN Tee Female swivel on Run

Part no	AN-Dim
9261-03	-03
9261-04	-04
9261-06	-06
9261-08	-08
9261-10	-10
9261-12	-12



AN Tee Female swivel on Side

Part no	AN-Dim
9251-03	-03
9251-04	-04
9251-06	-06
9251-08	-08
9251-10	-10
9251-12	-12

Aluminium adapters



Straight Female AN Swivel Coupling

Part no	AN-Dim	AN-Dim
9151-03	-03	-03
9151-04	-04	-04
9151-06	-06	-06
9151-08	-08	-06
9151-08	-08	-08
9151-10	-10	-10
9151-12	-12	-12
9151-16	-16	-16



90° Male AN to Male Swivel NPT

Part no	AN-Dim	Thread
9221-03	-03	1/8
9221-04	-04	1/8
9221-44	-04	1/4
9221-06	-06	1/4
9221-62	-06	1/8
9221-66	-06	3/8
9221-07	-08	1/4
9221-08	-08	3/8
9221-88	-08	1/2
9221-10	-10	1/2
9221-11	-10	3/8



AN Male Weld Adapter

Part no	AN-Dim
9971-04	-04
9971-06	-06
9971-08	-08
9971-10	-10
9971-12	-12
9971-16	-16



AN Port Adapter ("O" Ring Seal)

Part no	AN-Dim	Thread
9850-64	-06	7/16-20
9850-65	-06	1/2-20
9850-06	-06	9/16-18
9850-68	-06	3/4-16
9850-86	-08	9/16-18
9850-08	-08	3/4-16
9850-81	-08	7/8-14
9850-09	-10	3/4-16
9850-10	-10	7/8-14
9850-11	-10	1 1/16-12
9850-13	-12	7/8-14
9850-12	-12	1 1/16-12



Port Plug ("O" Ring Seal)

Part no	Thread
9814-03	3/8-24
9814-04	7/16-20
9814-06	9/16-18
9814-08	3/4-16
9814-10	7/8-14
9814-12	1 1/16-12
9814-16	1 5/16-12

Aluminium adapters



AN Reducer ("O" Ring Seal)

Part no	AN-Dim Inv.	AN-Dim Unv.
9894-43	-04	-03
9894-64	-06	-04
9894-86	-08	-06
9894-04	-10	-08
9894-09	-12	-08
9894-10	-12	-10
9894-11	-16	-12

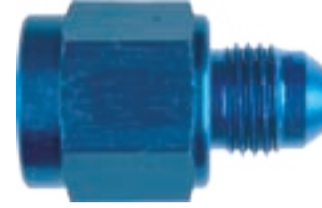

Flare Reducer

Part no	AN-Dim Inv.	AN-Dim Inv.
98920-64	-06	-04
98920-84	-08	-04
98920-86	-08	-06
98921-04	-10	-04
98921-06	-10	-06
98921-08	-10	-08
98921-26	-12	-06
98921-28	--12	-08
98921-20	-12	-10
98921-60	-16	-10
98921-62	-16	-12



Carburetor / Power Steering
Fuel Pump / Fuel Injection Adapters

Part no	AN-Dim	Thread	Typical Application
9919-41	-06	5/8-20	Carter / Edelbrock
9919-42	-06	9/16-24	Single Inlet Holley
9919-43	-06	7/8-20	Dual Feed Holley
9919-44	-06	M12 x 1,5	Weber
9919-45	-06	M12 x 1,25	Dellorto / Solex / Mikuni
9919-46	-06	1/2-20	Power Steering / Fuel Pump - 5/16 Tube Inverted Flare
9919-47	-06	5/8-18	Power Steering / Fuel Pump - 3/8 Tube Inverted Flare
9919-48	-08	7/8-20	Dual Feed Holley
9919-49	-06	7/8-20	Rochester
9919-50	-06	11/16-18	Power Steering Inverted Flare
9919-51	-06	7mm Banjo bolt	Dellorto
9919-52	-06	1"-20	Rochester 75-
9919-53	-06	M10 x 1	Weber
9919-54	-06	M14 x 1,5	Power Steering / Fuel Injection - O-Ring Seal
9919-55	-06	M16 x 1,5	Power Steering / Fuel Injection - O-Ring Seal
9919-56	-06	M18 x 1,5	Power Steering - O-Ring Seal
9894DBH	-06	M14 x 1,5	Fuel Injection Fem. O-Ring Seal
9894DBJ	-06	M16 x 1,5	Fuel Injection Fem. O-Ring Seal

Aluminium adapters



AN Cap

Part no	AN-Dim
9929-03	-03
9929-04	-04
9929-06	-06
9929-08	-08
9929-10	-10
9929-12	-12
9929-16	-16



AN Plug

Part no	AN-Dim
9806-03	-03
9806-04	-04
9806-06	-06
9806-08	-08
9806-10	-10
9806-12	-12
9806-16	-16



Tube Nut

Part no	AN-Dim
9818-03	-03
9818-04	-04
9818-06	-06
9818-08	-08
9818-10	-10
9818-12	-12
9818-16	-16



Tube Sleeve

Part no	AN-Dim
9819-03	-03
9819-04	-04
9819-06	-06
9819-08	-08
9819-10	-10
9819-12	-12
9819-16	-16



Banjo Adapter

Part no	AN-Dim	Hole Size
776-04M10	-04	M10
776-06D	-06	9/16
776-06M12	-06	M12
776-06M14	-06	M14
776-06M16	-06	M16
776-08M16	-08	M16

Alu Adapter NPT



Female Coupling

Part no	Thread
9910-01	1/8
9910-02	1/4
9910-03	3/8
9910-04	1/2
9910-06	3/4



Male Nipple

Part no	Thread
9911-01	1/8
9911-02	1/4
9911-03	3/8
9911-04	1/2
9911-06	3/4



90° Elbow Internal/External Pipe Thread

Part no	Pipe Thread
9914-01	1/8
9914-02	1/4
9914-03	3/8



45° Elbow Internal/External Pipe Thread

Part no	Pipe Thread
9915-01	1/8
9915-02	1/4
9915-03	3/8



90° Elbow Internal Pipe Thread

Part no	Pipe Thread
9916-01	1/8
9916-02	1/4
9916-03	3/8



Tee Internal Pipe Thread

Part no	Pipe Thread
9917-01	1/8
9917-02	1/4
9917-03	3/8



Reducer Pipe Bushing

Part no	Female. Thread	Male. Thread
9912-01	1/8	1/4
9912-02	1/4	3/8
9912-03	1/8	3/8
9912-04	3/8	1/2
9912-05	1/4	1/2
9912-06	1/8	1/2
9912-070	1/2	3/4
9912-08	3/8	3/4
9912-09	1/4	3/4
9912-10	3/4	1
9912-11	1/2	1
9912-12	3/8	1
9912-13	3/4	1 1/4



Plug Socket Head

Part no	Thread
9932-01	1/16
9932-02	1/8
9932-03	1/4
9932-04	3/8
9932-05	1/2
9932-06	3/4

Alu Adapter JIC/mm



JIC / Metric Conv.

Part no	AN-Dim	Thread
305-03-31D	-03	M10 x 1
305-04-31D	-04	M10 x 1
305-06-31D	-06	M10 x 1
305-06-42D	-06	M12 x 1,25
305-06-55D	-06	M14 x 1,5
305-06-65D	-06	M16 x 1,5
305-08-31D	-08	M10 x 1
305-08-45D	-08	M12 x 1,5
305-08-55D	-08	M14 x 1,5
305-08-65D	-08	M16 x 1,5
305-12-09D	-12	M20 x 1,5

JIC / Metric Conc.

Part no	AN-Dim	Thread
306-03-32D	-03	M10 x 1,25
306-03-41D	-03	M12 x 1
306-03-45D	-03	M12 x 1,5
306-03-55D	-03	M14 x 1,5
306-04-31D	-04	M10 x 1
306-04-32D	-04	M10 x 1,25
306-04-41D	-04	M12 x 1
306-04-55D	-04	M14 x 1,5
306-04-65D	-04	M16 x 1,5
306-06-32D	-06	M10 x 1,25
306-06-41D	-06	M12 x 1
306-06-52D	-06	M14 x 1,25
306-06-55D	-06	M14 x 1,5
306-06-65D	-06	M16 x 1,5
306-06-08D	-06	M18 x 1,5
306-06-09D	-06	M20 x 1,5
306-06-10D	-06	M22 x 1,5
306-08-45D	-08	M12 x 1,5
306-08-65D	-08	M16 x 1,5
306-08-08D	-08	M18 x 1,5
306-08-09D	-08	M20 x 1,5
306-08-10D	-08	M22 x 1,5
306-10-65D	-10	M16 x 1,5
306-10-08D	-10	M18 x 1,5
306-10-09D	-10	M20 x 1,5
306-10-10D	-10	M22 x 1,5
306-10-12D	-10	M26 x 1,5
306-12-08D	-12	M18 x 1,5
306-12-09D	-12	M20 x 1,5
306-12-10D	-12	M22 x 1,5
306-12-12D	-12	M26 x 1,5
306-12-16D	-12	M30 x 1,5
306-20-16D	-20	M30 x 1,5

Alu Adapter JIC/bsp



JIC / bsp Conv.

Part no	AN-Dim	Thread
741-03-03D	-03	R 1/8 bsp
741-03-03	-03	R 1/8 bsp
741-04-06D	-06	R 1/4 bsp
741-06-06D	-06	R 3/8 bsp
741-06-08D	-08	R 3/8 bsp
741-06-10D	-10	R 3/8 bsp
741-08-06D	-06	R 1/2 bsp
741-08-08D	-08	R 1/2 bsp
741-08-10D	-10	R 1/2 bsp
741-08-12D	-12	R 1/2 bsp
741-10-10D	-10	R 5/8 bsp
741-10-12D	-12	R 5/8 bsp